



INSTALLATION GUIDE

Guide for your AZ-225 Dual-Axis, Azimuth Drive Solar Tracker

Congratulations, you have purchased the finest solar tracker available. With proper installation, your tracker will provide years of trouble-free service while maximizing your solar power production.

Your tracker may include one of the following options: (Check your packing slip.):

- ◆ **Stainless Steel Hardware Option** - Recommended for high humidity and salt laden environments.
- ◆ **Wattsun Voltage Converter Option** - Required for PV Systems other than 24 VDC.
- ◆ **Manual Control Option** - Exterior switches so you may manually operate the tracker.

The tracker comes complete with all the hardware necessary for assembly and mounting the PV modules. The Wattsun™ Tracker requires a length of **Eight-Inch ID Schedule 40 Steel Pipe** for use as the pipe mast. Specifications for the pipe mast can be found on the data sheet for this particular tracker. **The steel mounting pipe and PV modules are not included. Your electrician should provide all additional array wiring, fusing, power disconnects, grounding equipment and electrical junction boxes.**

WARNING:

If the Wattsun™ Azimuth Solar Tracker is not installed to manufacturer's specifications, such failure to properly install unit may cause tracker malfunction and or serious bodily injury or death. This tracker moves, therefore the tracker should be situated away from anybody or anything that may come in contact with it as it moves.

KEEP CHILDREN AWAY FROM TRACKER AT ALL TIMES.

Array Technologies, Inc.
3312 Stanford NE
Albuquerque, NM 87107

Tel: 505-881-7567
Fax: 505-881-7572
URL: www.wattsun.com

**Copyright © Array Technologies, Inc.
All rights reserved.**

Wattsun™ is a trademark of Array Technologies, Inc.



Sixteen, BP 150 watt modules mounted on a Wattsun AZ-225 Tracker Drive.

**Installation Guide: Version 2.0
August 2005**

WARNING TO ELECTRICIAN OR INSTALLER

- ◆ **Please read this instruction manual completely.**
 - ◆ **If you are unfamiliar with NEC compliant solar electric installation, then consult with the dealer** that supplied your tracker. They should have the skill and expertise to supply you with the necessary wiring diagrams and the appropriate connection wire, grounding equipment, junction boxes and fusing.
 - ◆ **Failure to ground the array structure**, including each module frame, the aluminum tracker frame, the drive head assembly and the pipe mast may make the tracker susceptible to damage by lightning.
 - ◆ **Do not rely on the pipe mast to act as a ground rod.** It is not a reliable substitute for a properly installed ground rod.
 - ◆ **Please send in the Wattsun Tracker Warranty Card.** Array Technologies does not share any of the information provided on the warranty card.
-

- ◆ **Please leave this manual for the tracker owner(s).** It is their property and will help resolve any potential problems.
- ◆ **Please provide the following information for the owner:**

Serial Numbers: _____
Serial Number located on the controller Serial Number located on the drive assembly

Tracker Type: Dual-Axis Tracker is Standard on AZ-225

Controller is powered from: Battery Bank Array-Direct

System Type: Off-Grid/Remote Home Grid-Intertie - no battery backup Grid-Intertie - battery backup
 Water Pumping Other _____

PV Array: PV System Voltage is _____ VDC Number of Modules: _____

Module Manufacturer: _____ Module Model: _____

Mounting Pole Height above the Ground is: _____ FT

TABLE OF CONTENTS

SECTION	TITLE	PAGE
1	Installation of the Tracker Pipe Mast and Foundation.	5
2	Install the Azimuth Gear Drive Assembly on Top of the Pipe Mast	6
3	Install the Fork Extensions, Torque Tube & Elevation Actuator	8
4	Installing the Module Support Frame Assembly	14
5	Installing the Tracker Controller	17
6	Power Connection to the Elevation Actuator	24
7	Power Connection to the Tracker Controller	25
8	Operating the Tracker Controller	29
9	Setting the Azimuth Drive Motor Limits	31
10	W48-24 HD: Pre-Regulator for 48 VDC PV Systems	32
11	Manual Control Option	35
12	Periodic Maintenance	36
13	Suggested Grounding Methods for Wattsun Solar Trackers	37
14	Warranty	41
15	Addendum: “Über Tracker” Plate Assembly for HZ Torque Tubes	42

WARNING! WINDY CONDITIONS CAN EXERT EXTREME FORCES ON THE ARRAY, FOUNDATION, AND PIPE MAST OF YOUR TRACKER.

- 1.1) Choose an optimum solar location to install the PV array for in the ground mounting. The location should be free from obstructions. Keep in mind that over a period of time, that trees, shrubs, etc. may grow enough to obscure the PV array from the sun. Consult with your dealer for proper tracker spacing and alignment regarding multiple tracker installations.
- 1.2) Dig an appropriate sized hole for your tracker's foundation using a shovel, auger, or backhoe. The variables that affect the design of the foundation include: tracker size, pipe mast height, soil conditions, geographical location, weather and local building codes. Employ a qualified professional to design the foundation for your tracker.
- 1.3) A general rule of thumb is to have an equal amount of pipe underground as above the ground and a three-foot diameter reinforced concrete foundation. Please have a professional design the size and type of foundation required!
- 1.4) Use the appropriate length of 8" ID, Schedule 40 Steel Pipe in order to leave the recommended maximum pipe mast height protruding from ground. Consult your specific Wattsun Technical Data Sheet for the appropriate mast height and pipe diameter size. Note: If the recommended pipe mast height is exceeded, it may be necessary to telescope a larger diameter pipe in the lower portion and increase the foundation size in order to withstand the increased forces exerted during windy conditions.
- 1.5) Cut at least two pieces of re-bar or steel angle (more with 8 module or larger trackers), at lengths equal to the full diameter of the foundation. Weld re-bar onto (or drill holes and insert re-bar into) the underground portion of the pipe so that the pieces of re-bar form an 'x' pattern that remains parallel to the ground. When the tracker pipe mast is completely installed, the re-bar will be perpendicular to the pipe and parallel to the ground and protrudes radially outward into the concrete foundation. The re-bar acts as an "anti-rotation" device and will keep the pipe from spinning in the hole if the concrete shrinks back from the pipe.
- 1.6) Set the pipe into the hole and pour concrete around the pipe until it completely fills the hole. Also pour concrete into the pipe to secure the re-bar inserted in the bottom portion of pipe. Make certain the pipe is vertically plumb and allow concrete to set for at least 24 hours. If you fill the entire pipe mast with concrete, leave at least one foot of hollow pipe at top for azimuth drive assembly clearance.

SIMPLIFIED TRACKER FOUNDATION DIAGRAM
(Using recommended mast height from your Technical Data Sheet)

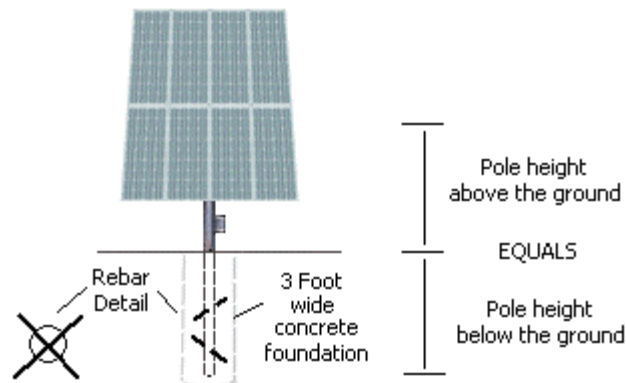

Array Technologies, Inc. assumes no liability for your foundation installation. Please consult with a local professional or your Wattsun Solar Tracker Dealer.

2.1) Northern or Southern Hemisphere installations.

For Northern Hemisphere installations, point the motor/gear assembly to 'true north' * and tighten the four set bolts to secure tracker to pipe mast. The set bolts should be tightened so that they dig into the pipe mast.

For Southern Hemisphere locations, point the motor/gear assembly to 'true south' * and tighten the four set bolts to secure tracker to pipe mast. The set bolts should be tightened so that they dig into the pipe mast.

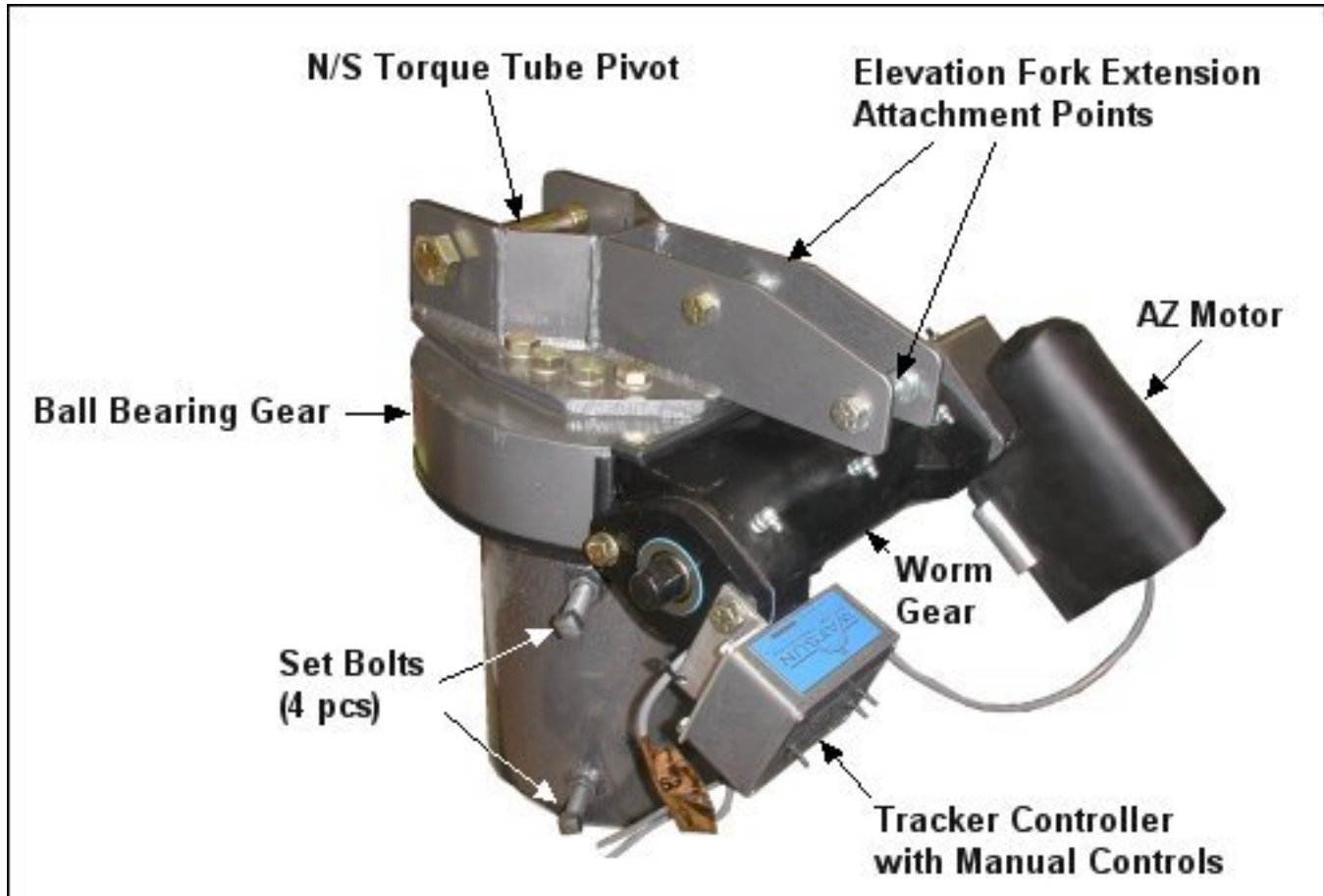

Tropical and Equatorial Installations are discussed in Section 3.5

*** Note:**

True north and south differ from magnetic north and south and depends on geographical location. Locate 'magnetic north' or 'magnetic south' using a compass and adjust your tracker setting accordingly. Your Wattsun Tracker Dealer can provide you with the Magnetic Declination for your area. The Array Technologies web site (www.wattsun.com) has links to geomagnetic data. You can find, or calculate, the magnetic declination for any place on the globe.

Perhaps the easiest way to find the North-South line is to get a copy of your local newspaper and find the Sunrise and Sunset times. Determine the time (hour and minute) that falls exactly halfway between Sunrise and Sunset. At the halfway or 'Solar Noon' point, anything that casts a shadow will do so along a North-South line. Get a friend to help hold up a length of wood or a stick of conduit straight up into the sky. Then stake out or mark the North-South shadow line.

VERY IMPORTANT! "OUT OF THE BOX" DRIVE ORIENTATION

The AZ-225 Drive orientation is preset at the factory and referenced to Solar Noon. The drive should be mounted facing due South, (Due North in the Southern Hemisphere.). The four set bolts “dig in” to the mounting pipe and secure the drive to the pipe mast.

SET BOLTS: The 4 "cup point" set bolts "dig and cut" in to the 8" ID SCH40 Steel Pipe Mast. Tighten the set bolts so that they put strong and equal pressure on the pipe mast. Each bolt should "show" and equal amount of thread when you are finished. **Each set bolt should be tightened to 100 Ft-Lbs of torque.**

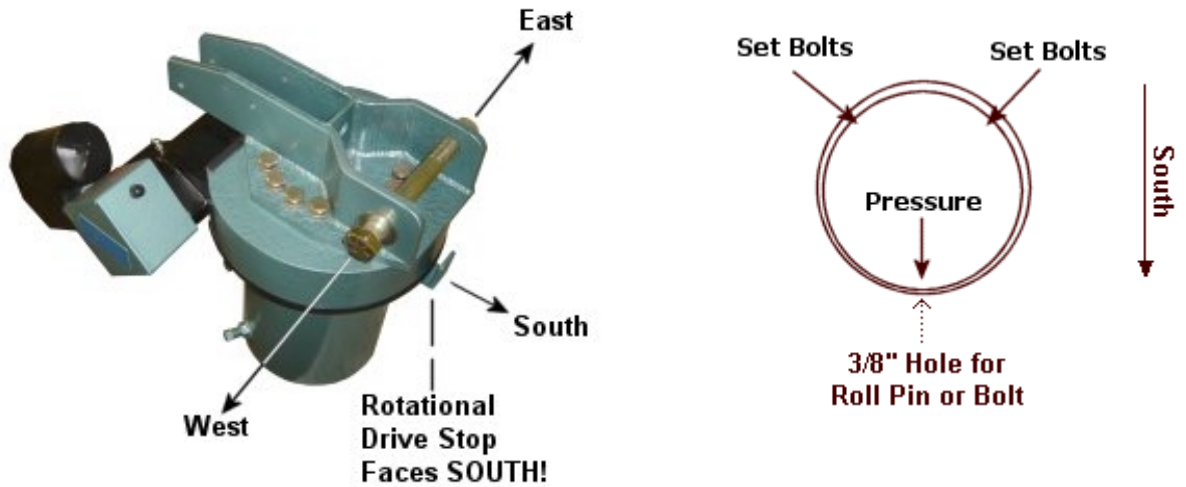

ROLL PIN: A three-eighths inch (3/8") diameter hole is predrilled in the midpoint of the south face of the drive. The hole accommodates the 3/8" roll pin. Once you are sure that the drive is facing due South, you can use the hole as a guide to drill a three-eighths inch (3/8") diameter hole into and through the wall of the mounting pipe. Then tap in the roll pin so that it penetrates through both the drive and pipe mast. Alternately, both holes could be threaded and a bolt could be used to "pin" the drive and mounting pipe together.



BOLT THE FORK EXTENSIONS ONTO THE DRIVE

(Most trackers are shipped from the factory with the lower fork extensions installed. Check the bolts to make sure that they did not loosen in transit.)

Bolt the Lower Fork Extensions onto the AZ-225 Drive. The forks angle downward and to the insides of the torque tube pivot holes on the drive. Each extension has two holes to secure it to the drive. That leaves a single hole at the end of each fork to bolt in the Elevation Actuator.

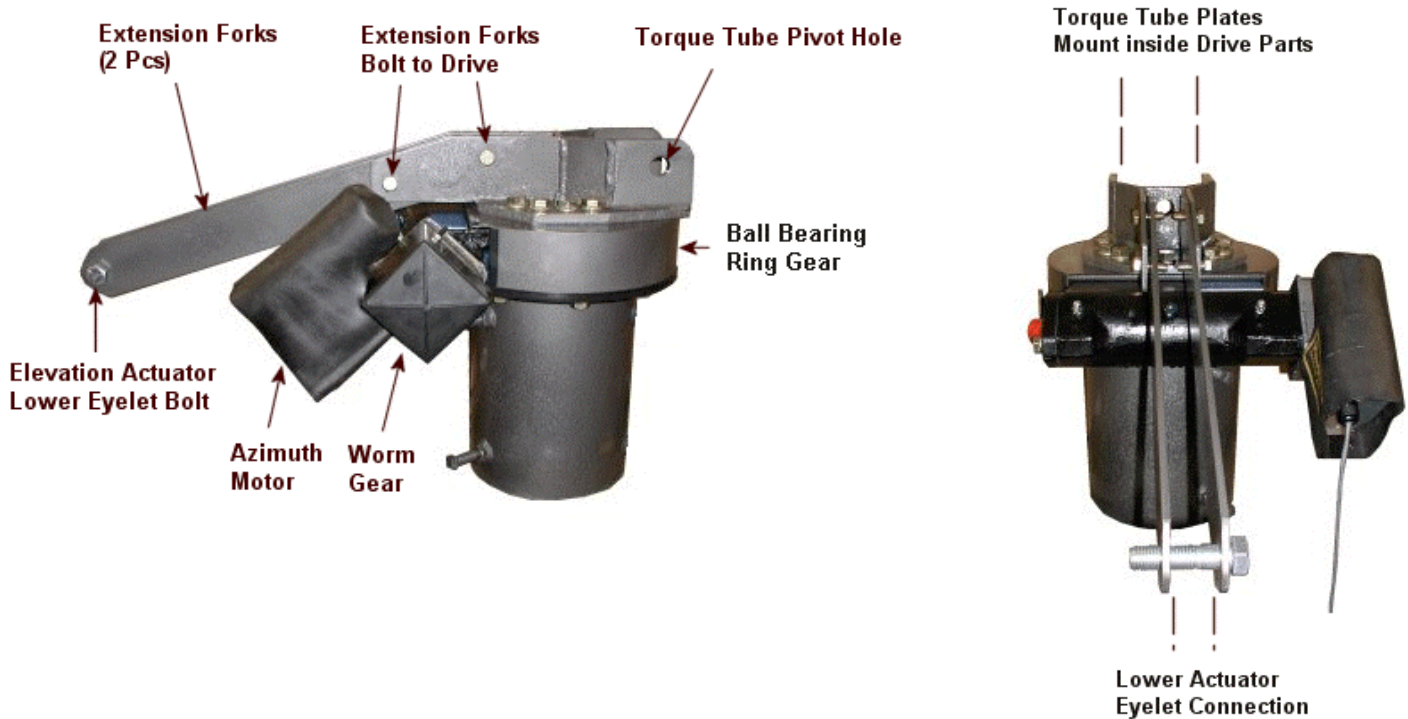

WARNING!

The AZ-225 Drive weighs from 170 to 220 pounds!

Do not use the Azimuth motor or tracker controller as "lift handles." You will damage the motor gearing or tracker controller if you put any unusual force on them.

You will have to be able to lift the AZ-225 Drive up, over and down on top of your mounting pole. Placing the drive on top of the pipe is at least a "two person" job. The drive is much easier to set using a boom and pulley arrangement or suspending it from a backhoe bucket or other appropriate method.

Make sure that the drive "seats" completely over the pipe. Back out the 4 set bolts if necessary to make sure that they do no catch on the top of the pipe. The 4 "cup point" set bolts "dig and cut" in to the steel pipe. Tighten the set bolts so that they put strong and equal pressure on the pipe mast. Each bolt should "show" an equal amount of thread when you are finished. **Each set bolt should be tightened to 100 Ft-Lbs of torque.**

TRACKER FRAME TORQUE TUBE

IDENTIFICATION:

DOES THE TRACKER HAVE A VERTICAL OR HORIZONTAL TUBE?

VTT: Vertical Torque Tubes have welded tabs and a painted finish.

HTT: Horizontal Torque Tubes do not have any welded pieces and generally have a galvanized finish.

VTT: VERTICAL TORQUE TUBE

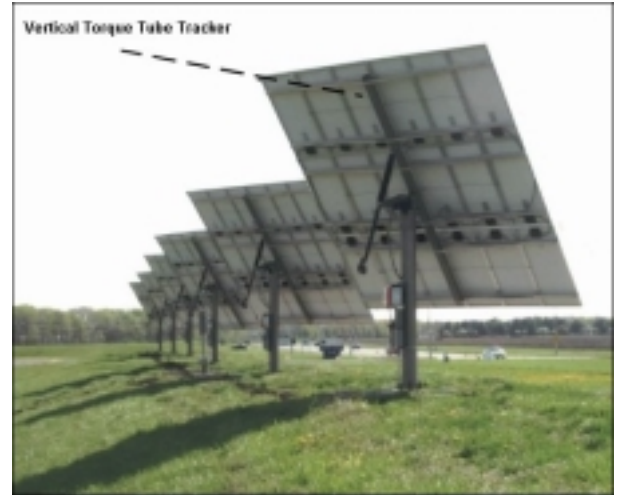
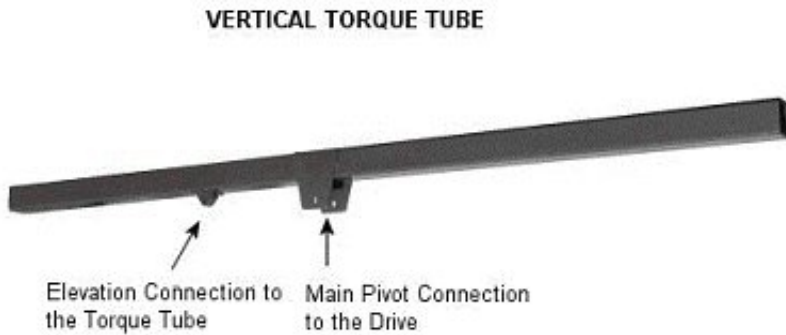

HTT: HORIZONTAL TORQUE TUBE



THE TORQUE TUBE DICTATES PORTRAIT OR LANDSCAPE ARRAY LAYOUT

Vertical Tube: Modules in "Portrait"



Horizontal Tube: Modules in "Landscape"



VTT: AZ-225 VERTICAL TORQUE TUBE INSTALLATION

(Bypass the VTT pages and refer to Horizontal Torque Tube Installation if you have a tube with no welds)

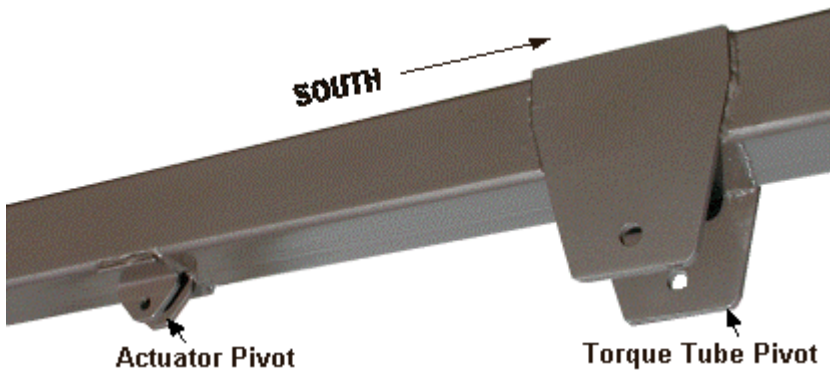

Bolt the Torque Tube onto the Drive.
 Make sure that the Elevation Actuator Pivot is on the same side of the tracker as the Lower Elevation Fork Extensions. Secure the torque with a rope if necessary to keep it from moving while you proceed

ELEVATION ACTUATOR ASSEMBLY FOR DUAL-AXIS OPERATION:

Do not unscrew the inner tube of the elevation actuator! This destroys the factory pre-set mechanical upper and lower limit switch settings. Install the elevation actuator. Center both the eyelet end (the top) of the elevation actuator inside the forks and the elevation actuator clamp eyelet (the bottom). Firmly tighten the nuts on the bolt threads.

North-South Torque Tube

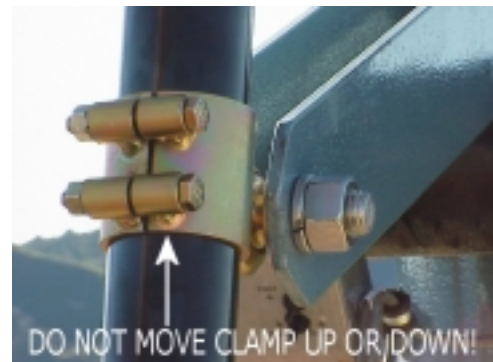
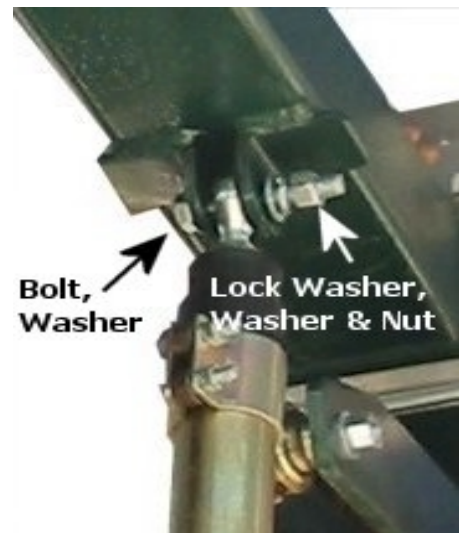
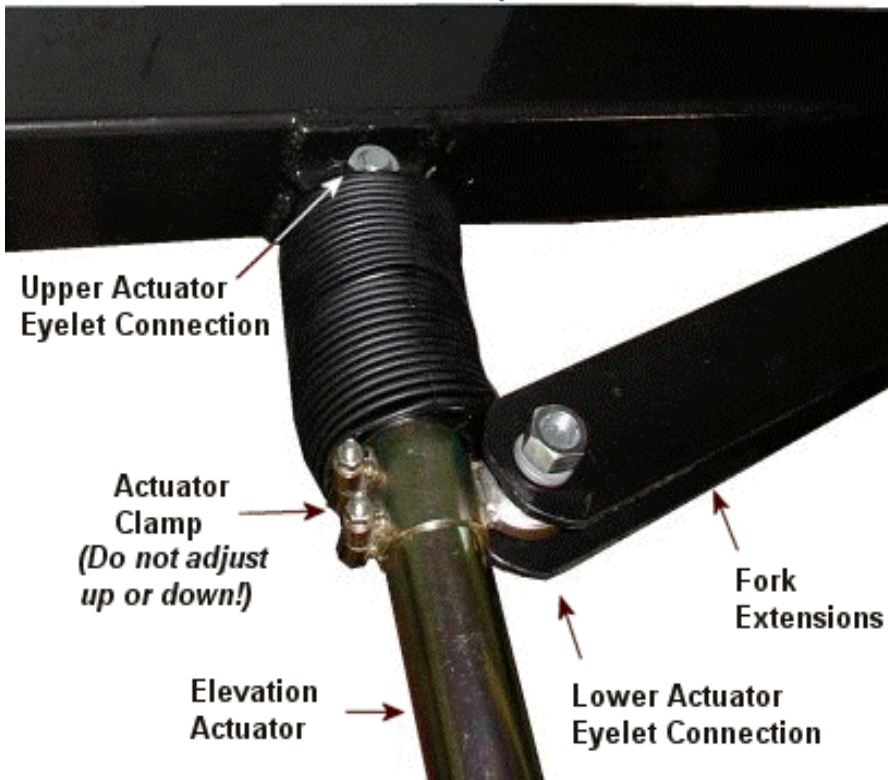

VTT: ELEVATION ACTUATOR CONNECTIONS TO THE TRACKER DRIVE

(Bypass the VTT pages and refer to Horizontal Torque Tube Installation if you have a tube with no welds)

Vertical Torque Tube

TOP ASSEMBLY

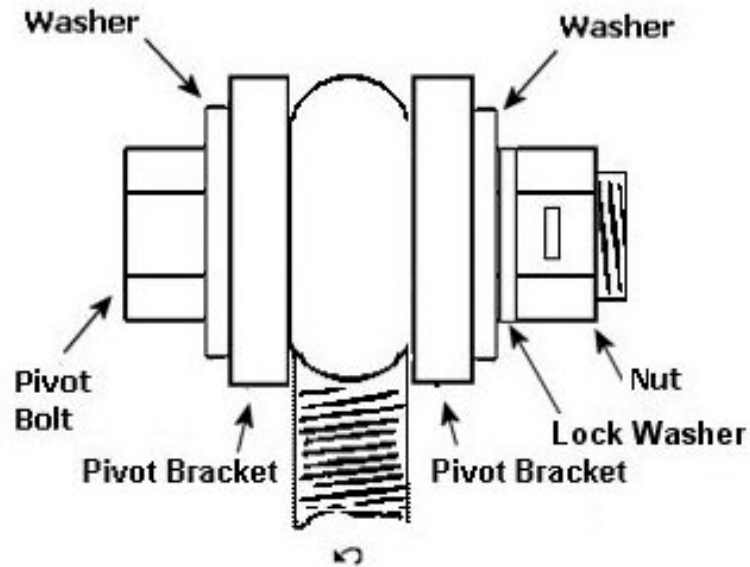

Do not allow actuator to unscrew from factory preset!

BOTTOM ASSEMBLY

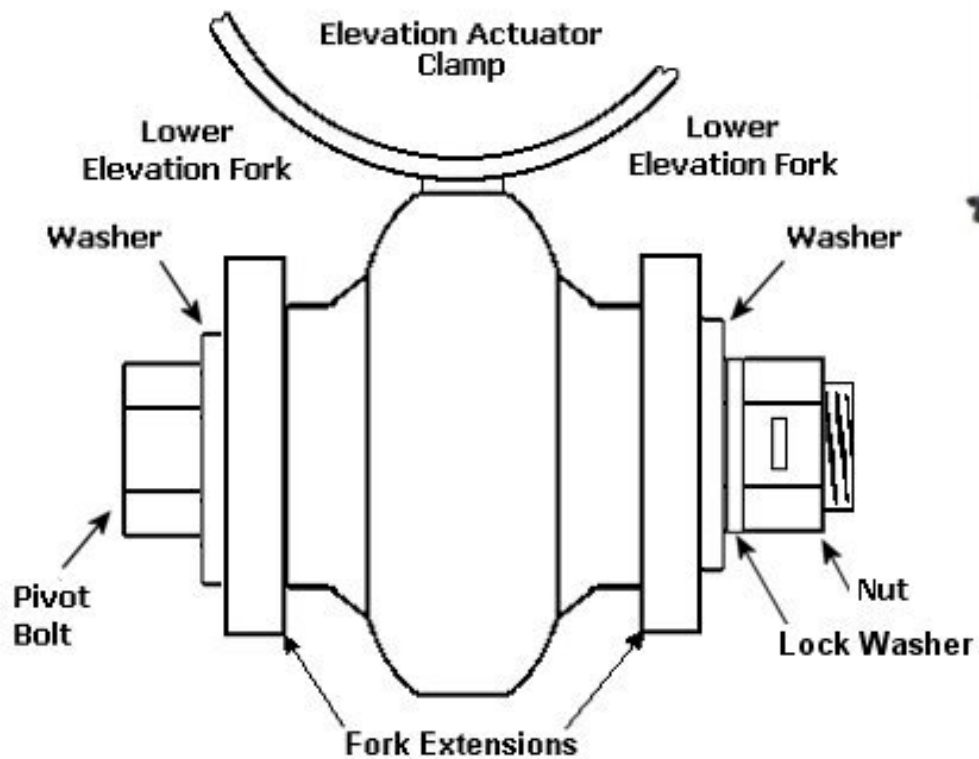

HTT: AZ-225 HORIZONTAL TORQUE TUBE INSTALLATION

(Go back and refer to Vertical Torque Tube Installation pages if you have a tube with welded tabs)

Consult the diagrams below for the bolt connections. Tighten the U-bolt Nylock nuts to 70 Ft-Lbs of torque



TIGHTEN NYLOCK 5/16" U-BOLT NUTS EVENLY.

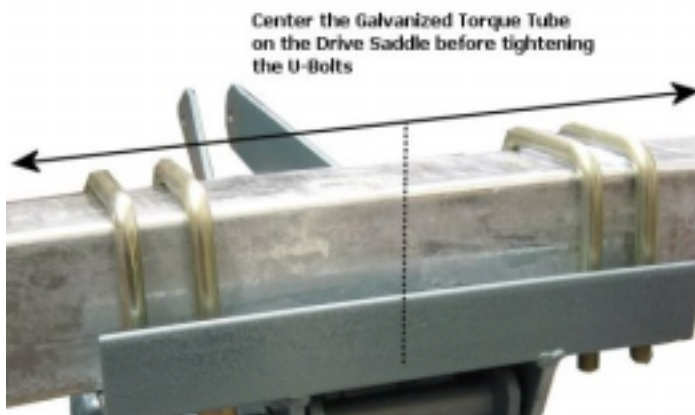

TIGHTEN EACH NYLOCK NUT TO 70 FT-LBS OF TORQUE.

ELEVATION ACTUATOR ASSEMBLY FOR DUAL-AXIS OPERATION:

Do not unscrew the inner tube of the elevation actuator! This destroys the factory pre-set mechanical upper and lower limit switch settings. Install the elevation actuator. Center both the eyelet end (the top) of the elevation actuator inside the forks and the elevation actuator clamp eyelet (the bottom). Firmly tighten the locknuts on the bolt threads.

UPPER CONNECTION

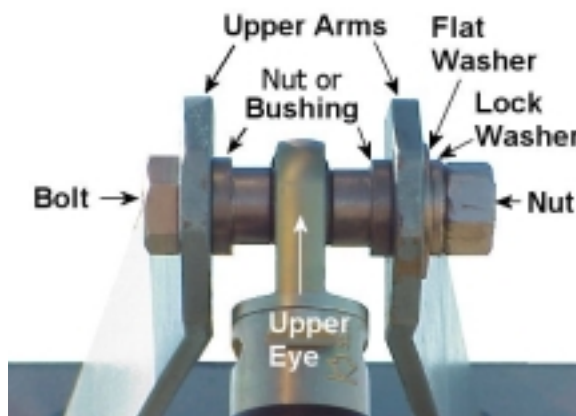

LOWER CONNECTION

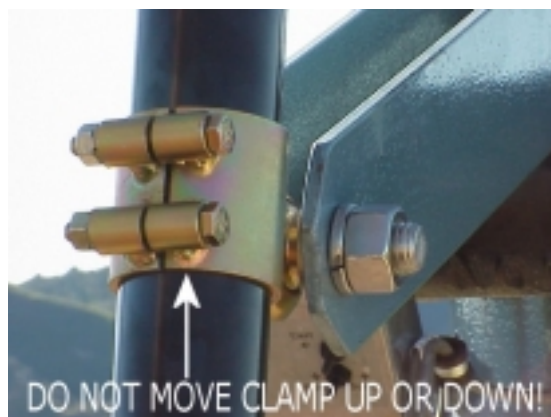

HTT: ELEVATION ACTUATOR CONNECTIONS TO THE TRACKER DRIVE

(Go back to the Vertical Torque Tube Installation section if you have a tube with welded tabs or fins.)

Horizontal Torque Tube

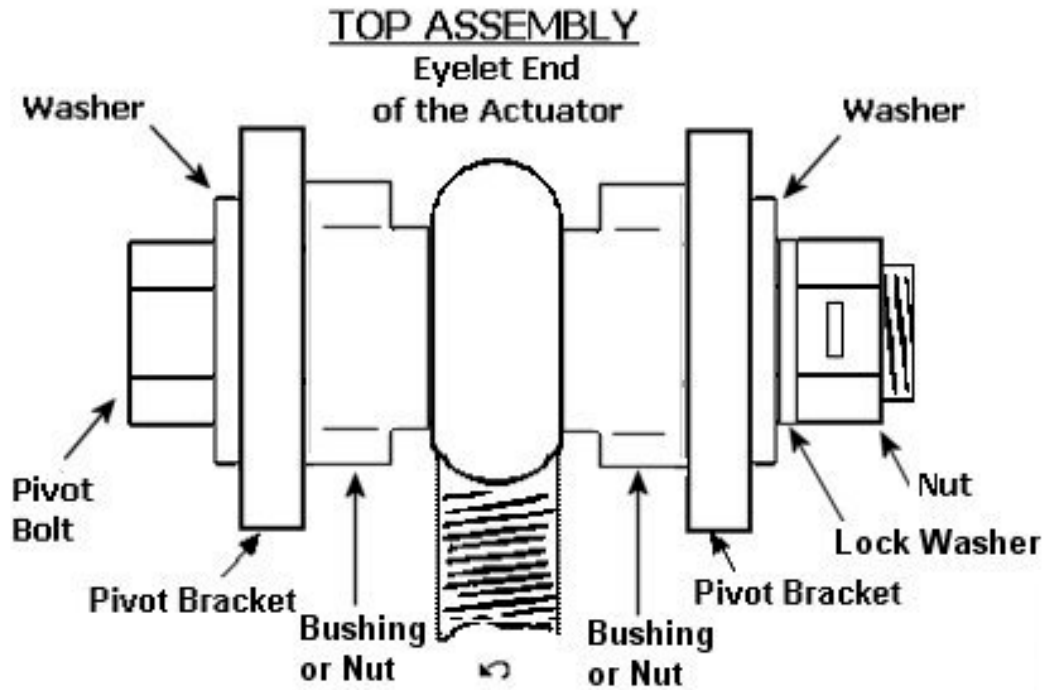

Do not allow actuator to unscrew from factory preset!

BOTTOM ASSEMBLY

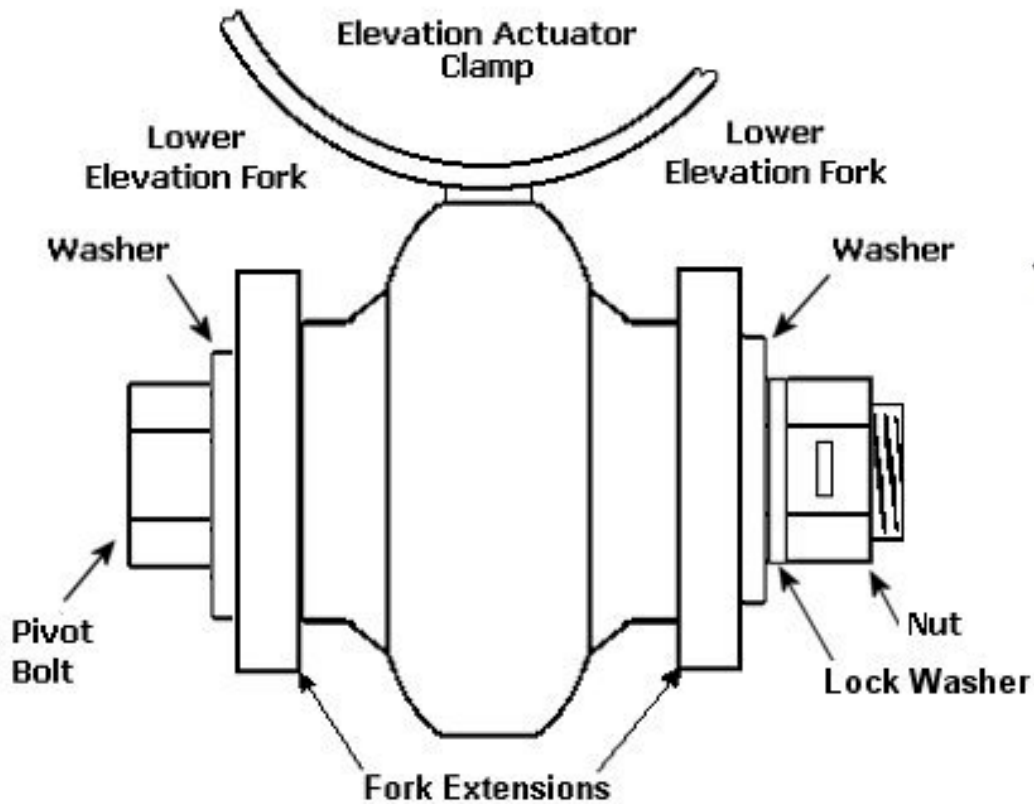

Section 4

Install the Module Support Frame onto the North/South Torque Tube

SECTION 4 NOTES: Nearly every nut and bolt will be left "finger-tight" until all the modules are mounted and the frame is "squared-up." So allow for a small amount of "play" when putting the array together. You will snug up all the bolts and nuts when all the modules are mounted and the frame is complete.

Installation Tip: The PV modules may be mounted to the struts at this time - prior to installation onto the torque tube assembly. This removes the difficulty of mounting each individual module to the struts while you working off a ladder or above your head.

However, placing the heavier, assembled module sub-array onto the torque tube assembly requires at least two people. For either application, the web of the module mounting struts must be oriented toward the outer ends of the modules.

NOTE: Your module-mounting configuration depends on the manufacturer and module that you selected. Consult your Technical Data Sheet for details. Generally the longer dimension of the module aligns along the North-South Axis and is parallel to the torque tube. Remember that the module struts bolt to the intermediate holes on the modules. The number of struts and angles in your tracker can vary from those shown in the diagrams in this section.

4.1) Install the module mounting struts and angle support brackets onto the Torque Tube

Your frame is one of two types: 2" aluminum module struts with 2-1/4" endcap channel OR 3" heavy duty aluminum module struts with no endcap channel.

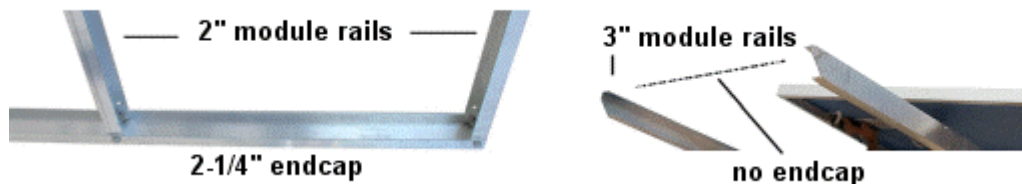

Place each module-mounting strut onto the top of the torque tube assembly. Make sure that the flat side of each strut is oriented toward the outer end of the modules. At the same time, the rectangular cutout area of the angle support bracket should be placed onto the underside of the torque tube assembly. Insert and loosely secure U-bolts with the appropriate washers and nuts.

Next, bend each end of the angle support bracket upward to meet the web of the module mounting struts. The holes on both the angle support bracket and the module-mounting channel will line up. Insert bolts and loosely secure the nuts.

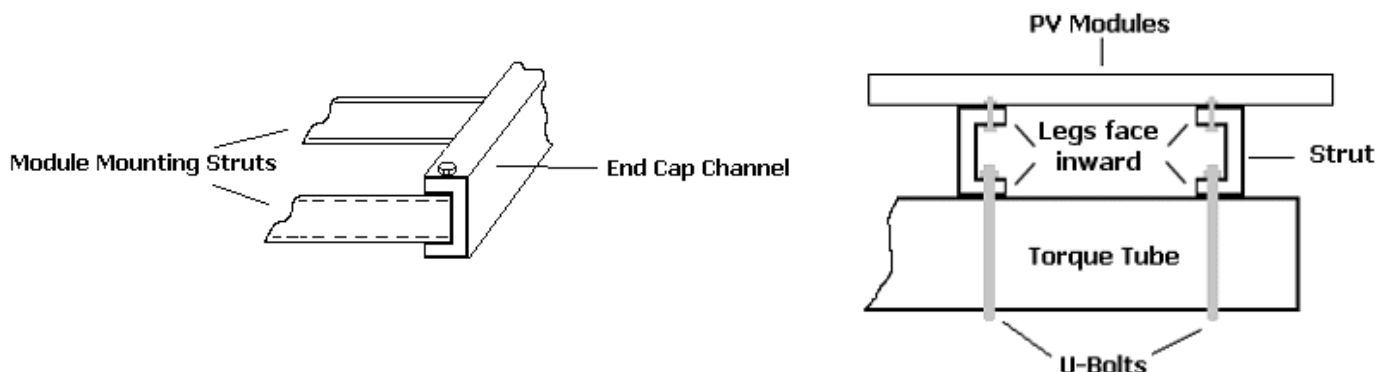

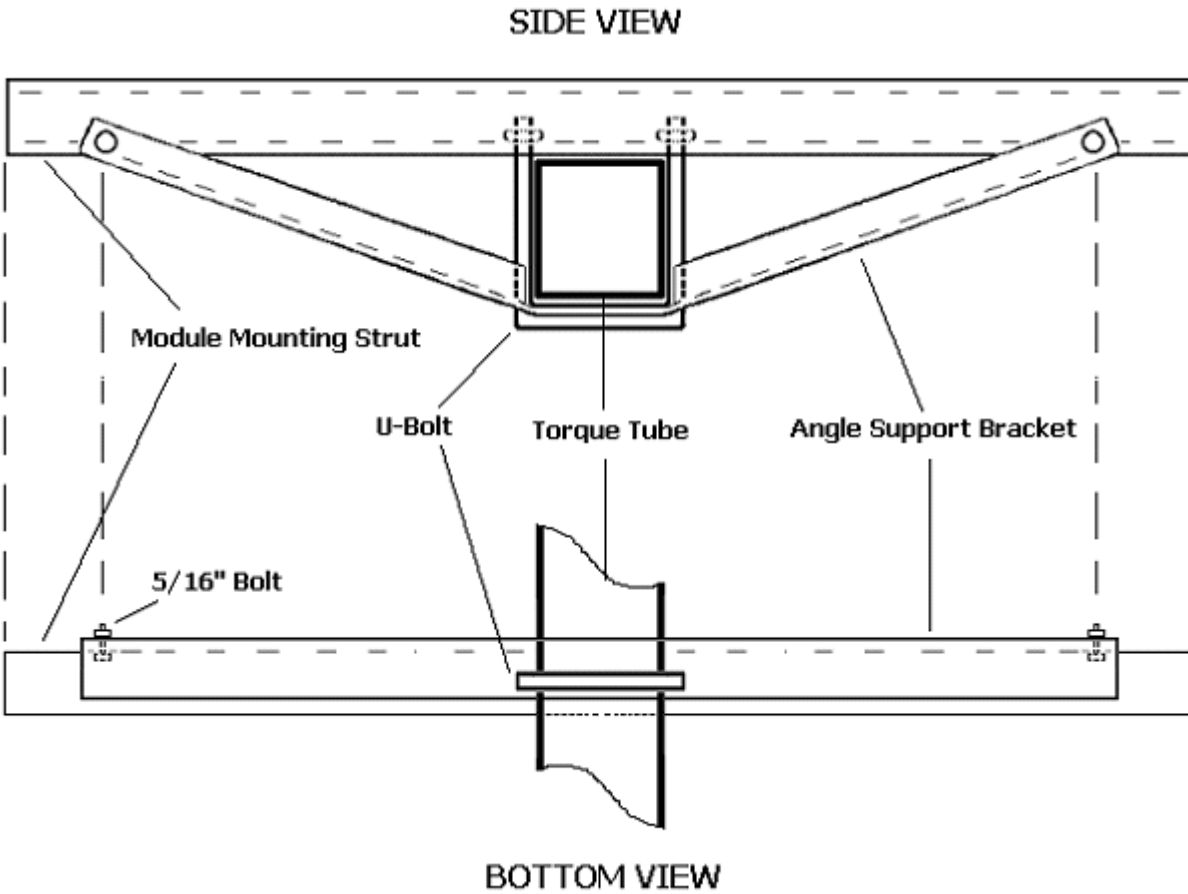

Tracker Frames with Endcap Channel

Once all the 2" mounting struts are bolted to the torque tube assembly, place the 2-1/4" end cap channel over the ends of the module mounting struts. Tap them into place. Insert the bolts and loosely tighten the nuts. Make sure that the whole strut and end cap channel assembly is centered and "squared up" on the torque tube.

4.2) For All Frames:

Mount the modules onto the struts. The modules align and mount using the four intermediate holes on the long sides of the module. Use the stainless steel bolts, washers and lock washers provided. The procedure is bolt – washer – pass through the module rail and then the serrated nut. The nut should "dig in" to the

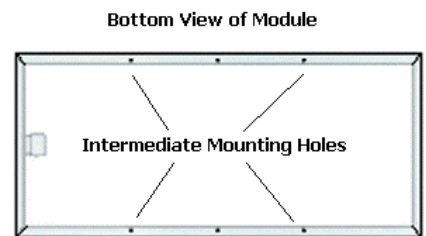

module rail.

Make sure the array of modules is centered on the torque tube assembly. Securely tighten the U-bolts so that they dig into the corners of the N/S torque tube. Tighten any nuts and bolts thoroughly that you left loose during assembly.

**BUILDING THE FRAME AND RACKING THE MODULES:
DO YOU MOUNT ONE PIECE AT A TIME OR BUILD SUB-ARRAYS?**

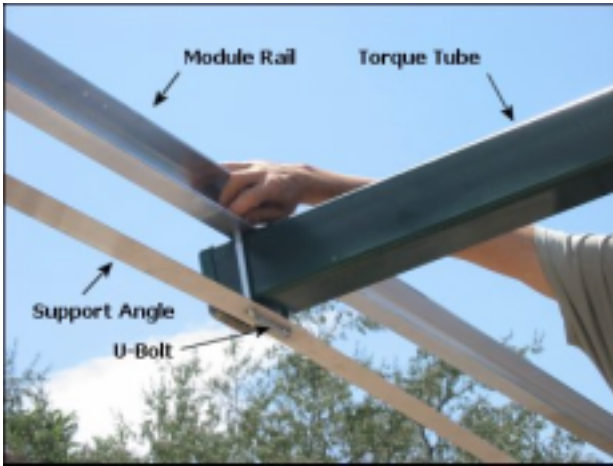

Module Rail & Support Angle Detail
From the bottom up the Procedure is:
Bolt > Support Angle > Tube > Rail > Washer > Nut



One installer, one piece at a time approach.
Modules are being used to “square-up: the frame.
Notice how the modules overhang the Rails.



Sub-Array Approach: Requires a lot of people power.
Notice that the rails bolt to the intermediate module holes.
Lift by the tracker rails only, not the module frames!



Lifting and bolting the sub-array onto the tube.
Typically a 3-person job: 2 lifters, 1 bolter.
Lift by the tracker rails only, not the module frames!



The “one piece at a time” approach can get very tiring. The installer is working with their arms and hands above their head. We encourage installers’ to wear a Hard Hat.

Leave all frame and module bolts “finger tight.” Once you finish the frame building and module mounting, you can go back and “square up” the array. Then tighten all nuts with a wrench.

NOTE: If you ever “under populate” the array frame, leave any unused space at the top of the frame. If the frame is not totally filled out, then the greatest weight should be on the lower sections of the frame.

WARNING! PLEASE READ THIS GUIDE COMPLETELY BEFORE CONNECTING POWER TO THE CONTROLLER. YOU CAN DAMAGE THE CONTROLLER OR INADVERTANTLY POWER UP THE TRACKER AND CREATE A HAZARDOUS SITUATION. NEVER APPLY POWER TO THE CONTROLLER OUTPUT WIRES! THE CONTROLLER WILL BE DAMAGED AND THE REPAIR CHARGE IS NOT COVERED UNDER WARRANTY.

**For Installations in the Tropics:
(20 degrees North latitude to 20 degrees South latitude)**

Array Technologies does not encourage the use of Dual-Axis Trackers in “low latitudes.” Wattsun Single-Axis Trackers are preferred in the tropics. Contact Array Technologies for performance data and recommendations.

The azimuth tracker works by rotating the PV array about the pipe mast then tilting the array to the proper elevation angle. Therefore, for installations near the equator it will be necessary to rotate the azimuth tracker 180 degrees twice a year. Depending upon the time of year, trackers in this region will find the sun anywhere from north, south, or directly overhead of its location, making manual rotation necessary.

For example, at the equator rotation of the tracker will need to occur on the first day of spring and the first day of fall. The array should point north on March 21st, and rotated 180 degrees to point south on September 23rd.

To rotate the tracker on the pipe mast, loosen the four set bolts on the azimuth drive, rotate the tracker and re-tighten. Marking the pipe mast for the two yearly positions, aids in seasonal adjustment. You must also leave sufficient output wire lengths from the array to allow for rotation.

24 VOLT TRACKER CONTROLLER SPECIFICATIONS

Controller input power specifications:

The input voltage range is 23 to 50 volts DC.

Use a Wattsun Voltage adapter to power the controller for nominal voltages other than 24 VDC.

Tracker controller wiring and drive motor wiring:

Do not connect the motor output wire harness to a power source! Connecting any of the controller output wires to the PV array or a power source will cause permanent damage to the controller and void the warranty.

Power supply connection options:

The input power leads are Red (positive) and Black (negative) wires in the two-wire cable mounted on the left-hand side of the controller chassis. The input wires are clearly marked with a tag.

Power consumption, including motors:

Less than 10 watt-hours per day.

Wattsun Tracker Controller
(Manual Control Option shown)

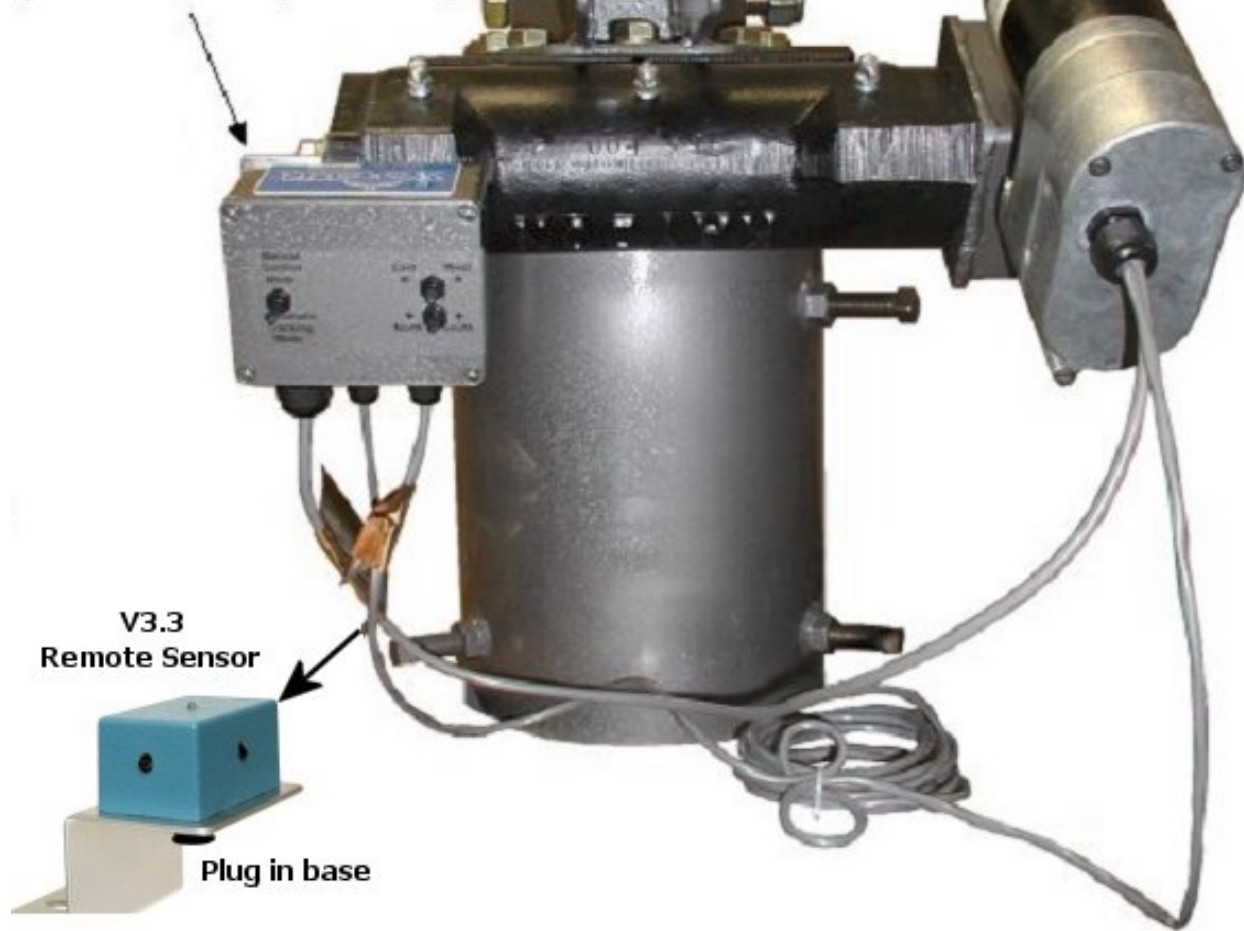

Y

OUR TRACKER CONTROLLER IS PREINSTALLED ON THE AZ-225 DRIVE.

WARNING!

MAKE THE "POWER IN" CONNECTION LAST!

DO NOT ENERGIZE THE WATTSUN SOLAR TRACKER CONTROLLER UNTIL YOU HAVE COMPLETED THE ENTIRE TRACKER INSTALLATION.

TWO ADDITIONAL CONTROLLER CONNECTIONS THAT GET MADE BY THE INSTALLER:



Sensor mounts on the top edge of the array. Center it on the top makes for a neat wire run. The remote sensor wire plugs into the base of the sensor. Twist the lock ring!



There is a two-wire "pig-tail" that is prewired into the azimuth motor. It needs to be connected to the elevation actuator motor.

WATTSUN TRACKER CONTROLLER: FUNCTION AND FEATURES.

OVERVIEW

Wattsun™ Solar Trackers utilize a patented, closed loop, optical sensing system to sense the sun's position and track it. The sun sensors are mounted on the remote chassis and feed information to the control electronics about the direct component of sunlight available, the diffuse amount of sunlight, the total amount of sunlight as well as the differential amount of sunlight on opposing sensors. Based on this information, the controller seeks to equalize the sunlight received by opposing sensors for each axis.

The controller circuitry automatically adjusts the tracker sensitivity. It increases the sensitivity with increased direct sunlight and decreases the sensitivity with scattered or diffused light - present during cloudy conditions. This enables the tracker to eliminate undue hunting in cloudy or overcast conditions when the sunlight is scattered. It also adjusts according to the total amount of light received by the sensors.

When the tracker controller is connected to a battery bank or constant power source. The controller can sense sunset, and return to the sunrise position in the evening. When it is powered directly from the PV array, the tracker returns to sunrise at first morning light. The controller uses energy integration circuitry, enabling the tracker to move with as little as 20ma of available current.

The tracker controller sends a signal to the DC gear motor that moves the PV array to a perpendicular position relative to the sun's rays. The motors are small, fraction HP, low voltage, gear motors that move the tracker into position. The gearing is designed such that high winds or other forces cannot drive the tracker back. Because they are DC drive motors, one polarity moves them in the forward direction and reversing the polarity moves them in the opposite direction. When the controller wants the tracker to move, it sends a signal of the appropriate polarity to the DC gear-motor. Once the tracker has moved to the "on track" position, the controller electrically "brakes" the motor to stop movement that results in greater tracking accuracy.

STANDARD FEATURES OF YOUR WATTSUN CONTROLLER

- ◆ Controller mounted on the drive for maximum accessibility.
- ◆ Sensor mounts independently of the main chassis.
- ◆ Dip switches to test the Azimuth and Elevation Limits.
- ◆ Dip switch to set nighttime Elevation (stow) position.
- ◆ Controller outputs are short circuit protected and will limit the output current to 3 amps.
- ◆ Inside controller chassis are light sensitivity adjustment potentiometers for Azimuth and Elevation.
- ◆ Controller is equipped with a 5-amp automotive spade type fuse (ATO) inside the controller chassis.
- ◆ Self-resetting thermal fuse that shuts off power to the tracker motors in case of obstruction.
- ◆ Filtering to protect the tracker motor against "noisy" PWM charge controllers.
- ◆ Improved lightning protection.

DUAL-AXIS NOTES

The controller prioritizes the azimuth (east/west) axis. If the azimuth axis is not on track, the elevation axis will not function. Once the azimuth axis has locked onto the sun and stops moving, the elevation axis adjusts. However, if you power the controller from a battery bank, you can choose to allow simultaneous azimuth and elevation motion.

NOTE

The Array Direct method is not recommended for powering Azimuth-Drive Trackers.

General Wiring Diagram for a Wattsun Solar Tracker Controller AZ-225 Drive manufactured after August 21, 2003

WARNING!
Backfeeding power into controller output wires will result in damage to the controller.

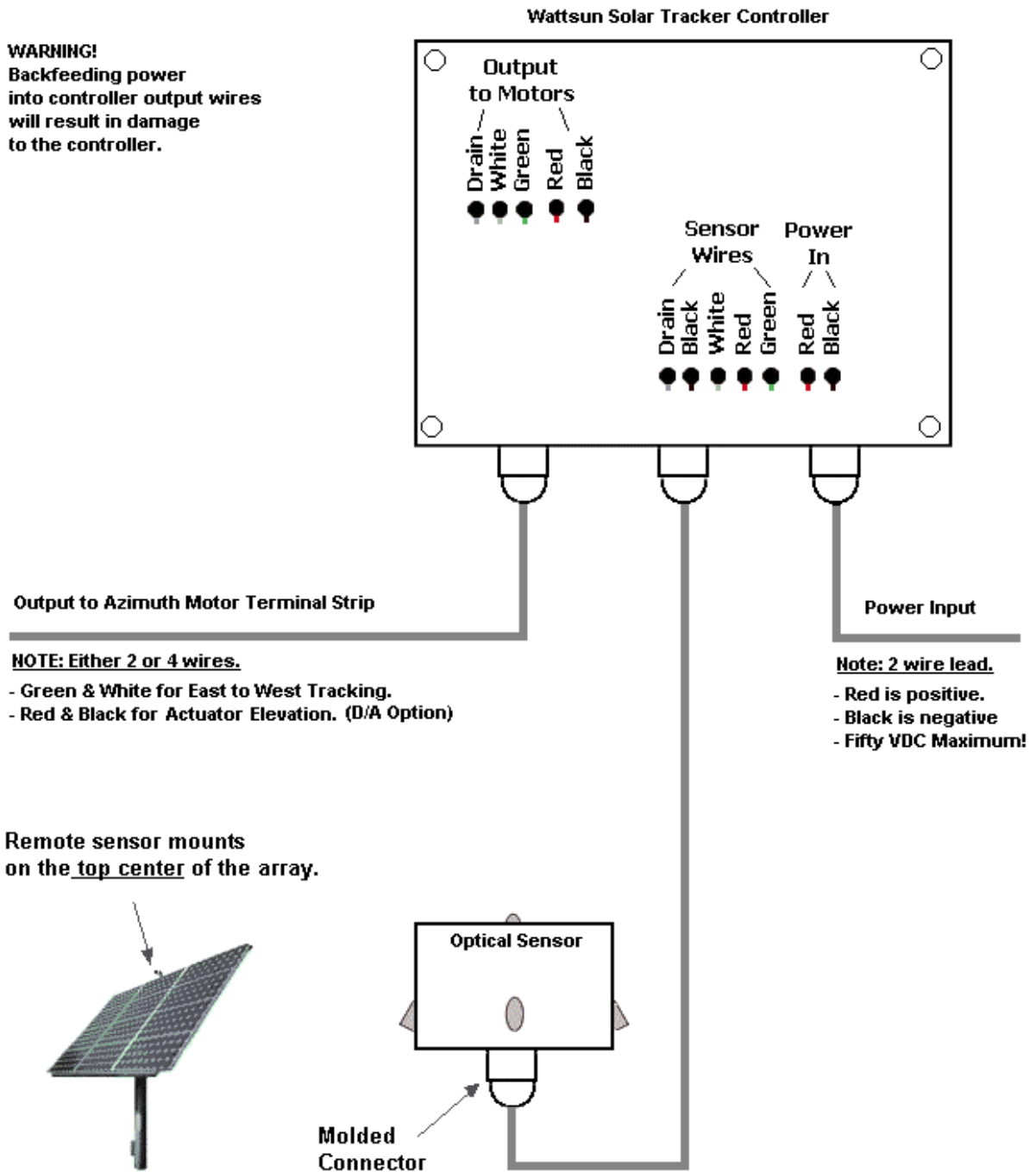

Terminal	Controller Output	Motor
1	White	Azimuth Drive
2	Green	Azimuth Drive
3	Red	Elevation Actuator
4	Black	Elevation Actuator

5.1) THE AZMUTH MOTOR TERMINAL STRIP (PRE-WIRED AT THE FACTORY)

It is unlikely that you will need to access the wiring inside the Azimuth Motor. The Azimuth Motor Terminal Strip is pre-wired at the factory. It serves as a central connection point for motor power wires. The 4-wire Controller output lead and the Elevation Actuator lead share entry into the Azimuth Motor Cover through the rain tight plastic strain relief.

A four-wire lead enters in from the Controller and is divided into two pairs. The first pair (White & Green) controls the East-West Azimuth movement. The second pair (Red & Black) "passes through" and controls the North-South elevation movement. The Elevation Actuator power lead exits azimuth motor cover through the strain relief and will be connected to the actuator motor by the installer.

AZ-225 AZIMUTH MOTOR WIRE CONNECTIONS

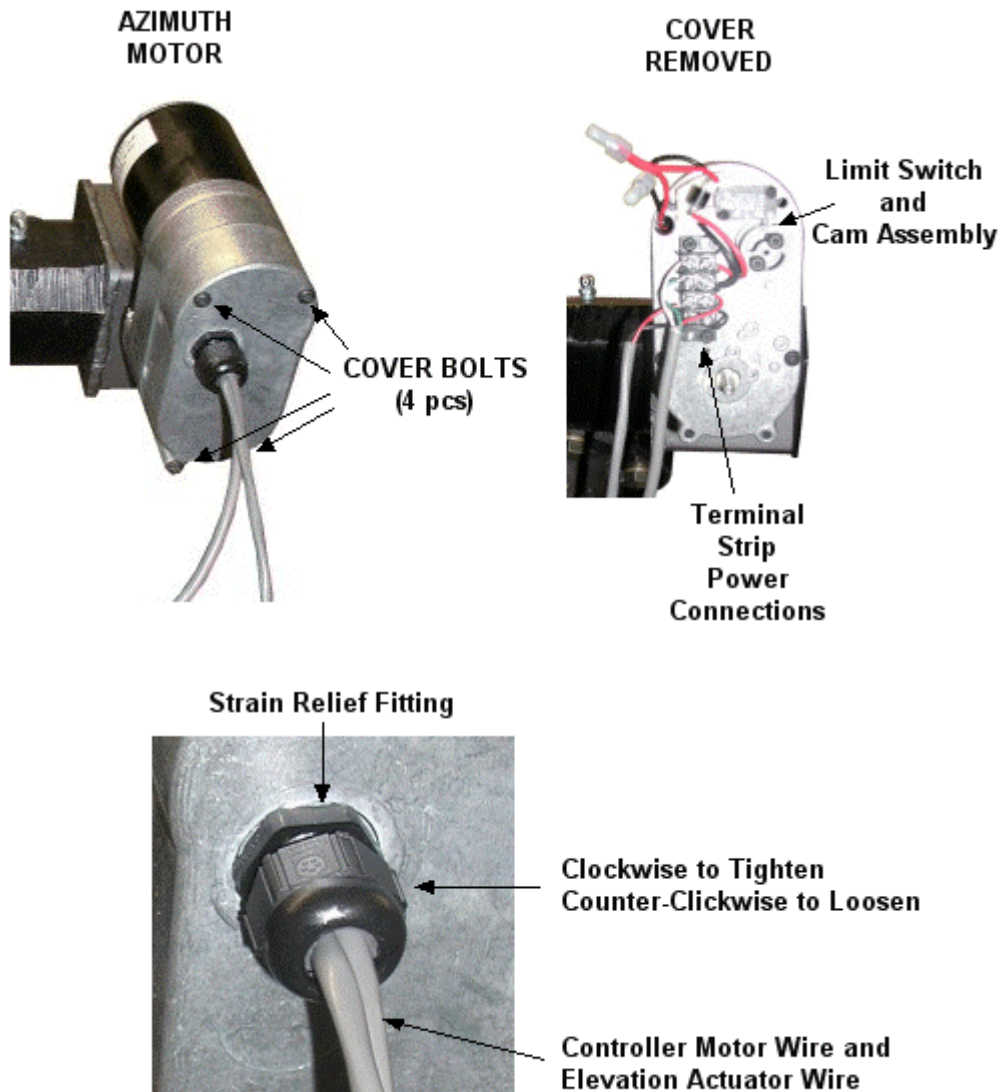

**AZIMUTH MOTOR: TERMINAL STRIP WIRING DIAGRAM
(POWER CONNECTIONS ARE PREWIRED AT THE FACTORY)**

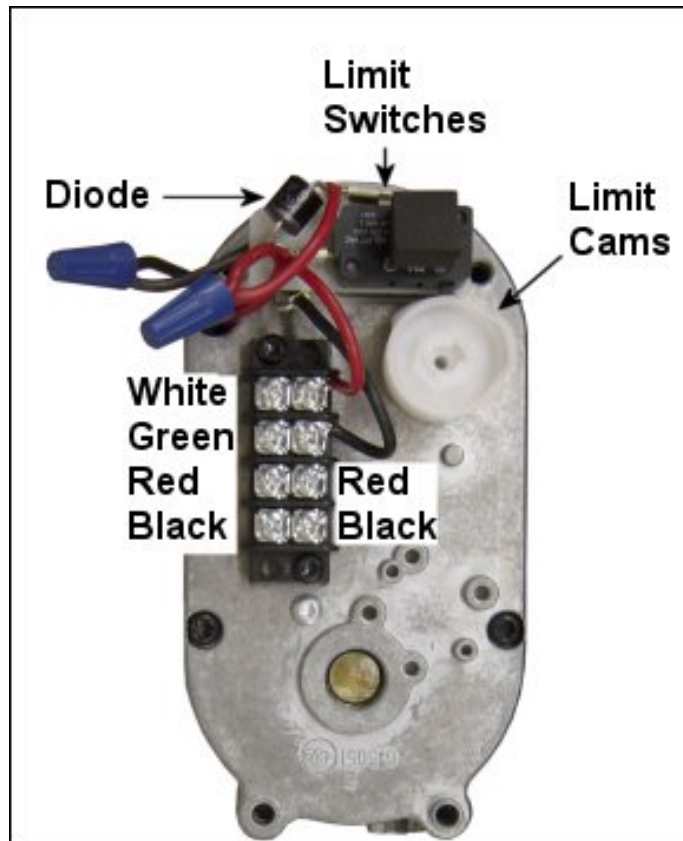
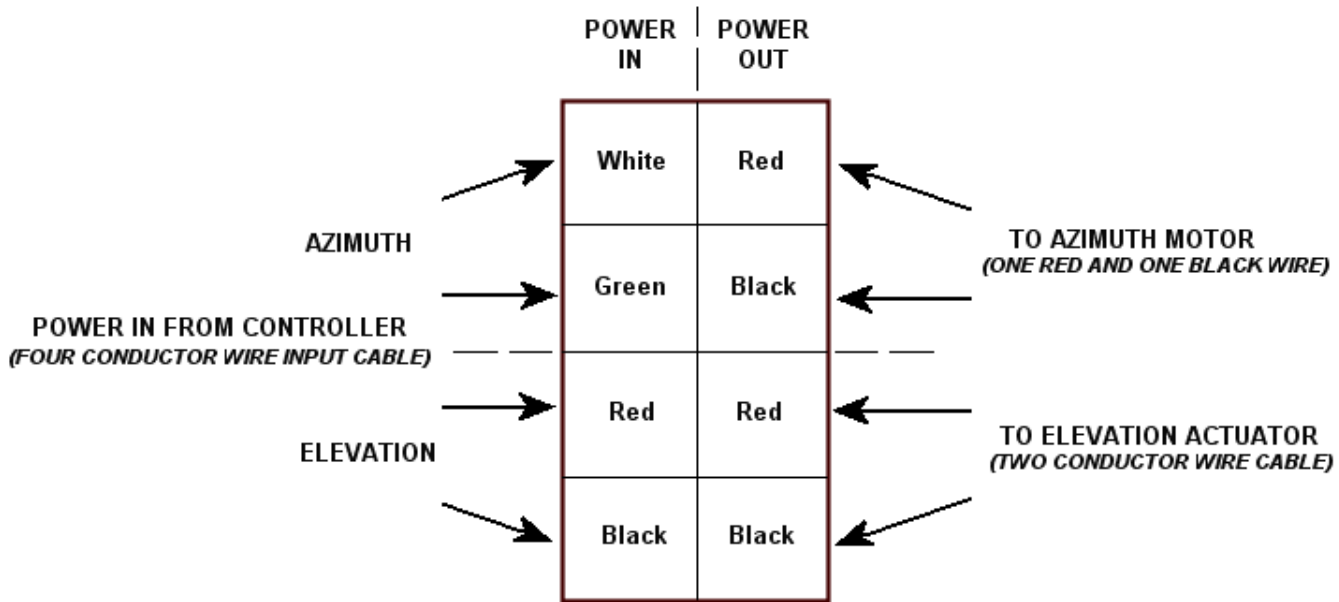

WARNING!
THE LAST CONNECTION MADE IS FROM YOUR POWER SOURCE TO THE TRACKER CONTROLLER! DO NOT ENERGIZE THE WATTSUN SOLAR TRACKER CONTROLLER UNTIL YOU HAVE COMPLETED THE ENTIRE TRACKER INSTALLATION.

5.2) MOUNTING THE REMOTE SENSOR



MOUNT THE REMOTE SENSOR ON THE TOP OF THE ARRAY

The sensor mounts on the **TOP CENTER (or near the center) of the PV array**. Most modules already have a hole in the frame that you can use. If your modules do not have an "end hole" then you will need to drill a 1/4" hole in the frame to mount the sensor. Slip a thin piece of wood between the module frame and

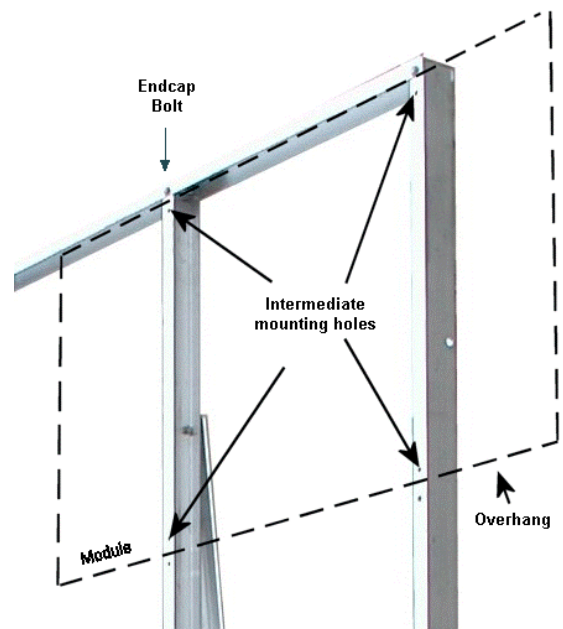
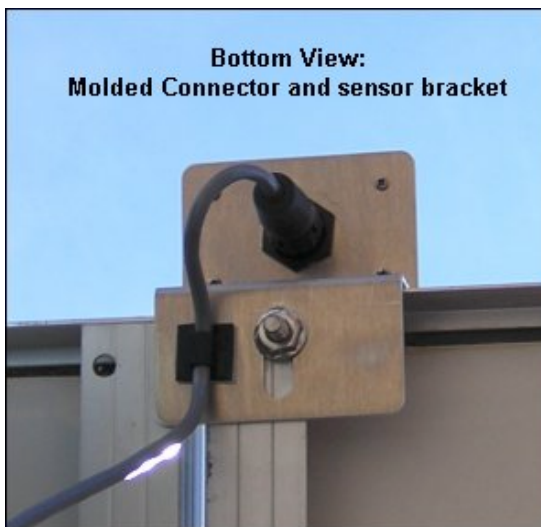

the back of the module. The wood "spacer" will keep you from inadvertently digging your drill bit into the back of the module once you have drilled through the frame.

If the modules in your array mount in "landscape" format and you have aluminum "endcaps" at the top and bottom of the array, then use the endcap mounting bolt and a strut near the center of the tracker. Make sure that the sensor has a clear view of the sky.

The wire coming from the sensor has a molded connector. It mates into the bottom of the controller. The controller connector has a groove inside to properly align the mating pieces. Match up the "tongue and groove" of both connectors, push them together and twist the locking ring to secure the connection.

THE V3.3 SENSOR ORIENTATION IS DIFFERENT FROM THE EARLIER V3.x VERSIONS!



The sensor needs to be above the plane of the array and have a clear view to the sky. Do not crowd it against the array or module frame. If the "eyes" don't have the freedom to see the sun then the tracker will have a tendency to tip up. The sensors function is to make sure that equal amounts of light fall on all four sides.

Be careful not to damage the clear sensor on top. It's function controls "return to the east" at night.

Warning! Never apply power to the actuator until it has been securely bolted into place. The linear actuator will tend to "unscrew" and will destroy the preset limit switch settings.

- 6.1) Loosen the 3 cover screws and remove the actuator cover. The plastic strain relief has been inverted to protect it during shipping. Flip it around, reseal and snake the actuator power wire through the strain relief.
- 6.2) The actuator power wire has two leads. One Red, one Black. Connect the actuator Black lead to the same screw terminal as the Red wire that feeds the actuator motor. Connect the actuator Red lead to the same screw terminal as the White wire that feeds the actuator motor. Replace the cover and tighten the strain relief. Be careful not to "pinch" or short any wires when closing the cover!

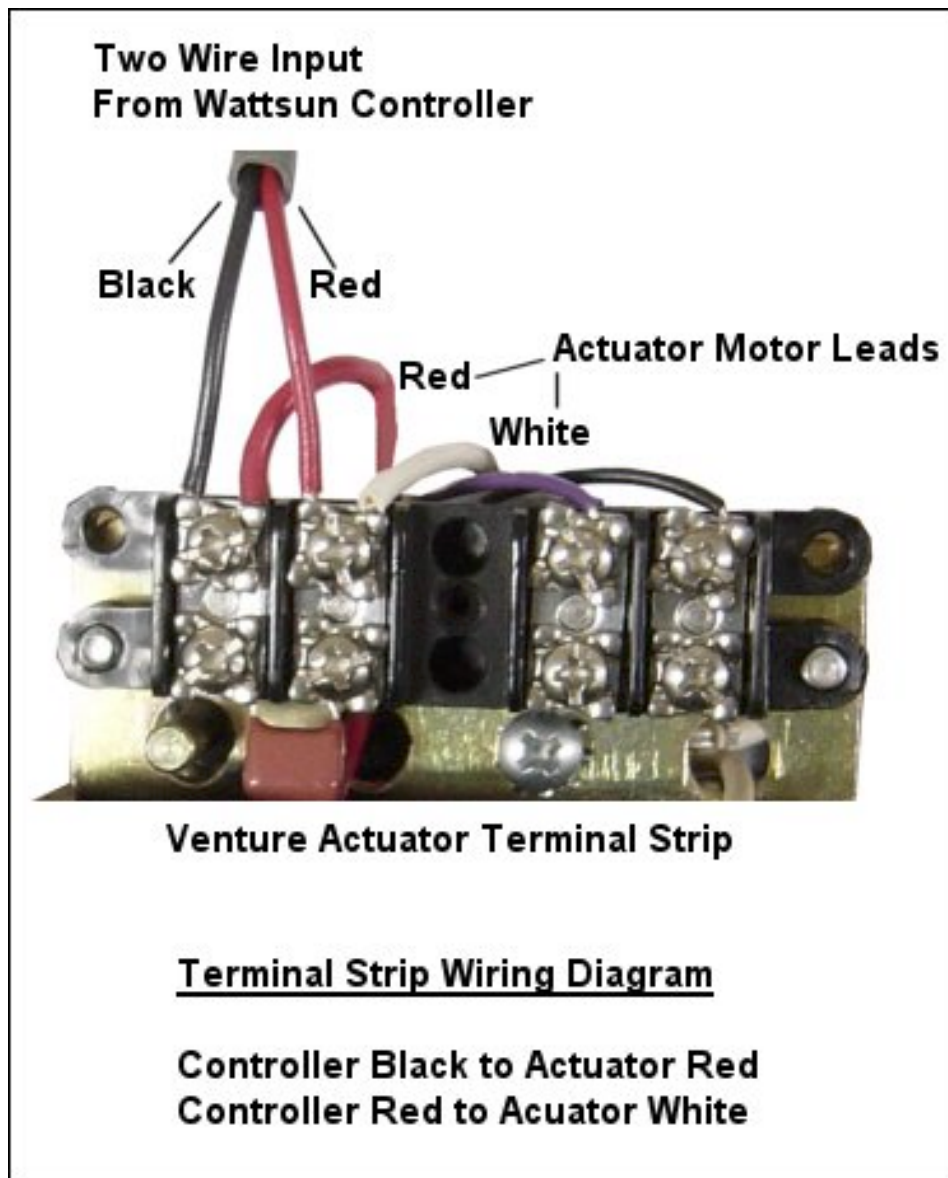

NOTE: This is a DC Motor! The voltage polarity of the wires coming in from the controller will "flip-flop" depending on which way the tracker wants to move. Standard DC color codes are "relative" when applied to the actuator motor connections. Wire the actuator as shown in the image above.

7.1) MAKING A DECISION ABOUT POWERING THE WATTSUN CONTROLLER

NOTE: The azimuth-tracking limit switches are preset at the factory to accommodate the maximum range of East-West azimuth tracking.

OPTION 1: Array Technologies recommends that you power your Wattsun Tracker Controller from a battery bank or grid-tied power source. The tracker will return to the East at sunset and the tracker has 270 degrees of azimuth tracking available. The dip-switch, sensor override features built into the controller are always available when you have constant power.

OPTION 2: (Discouraged with the AZ-225 Tracker!) If you power the controller from the array, the tracker returns East in the morning. The tracker is limited to only 180 degrees of azimuth tracking arc. You will have to reset the Azimuth Motor limit switch cams to reduce the East-West travel. The dip-switch, sensor override features built into the controller will only be available during the day.

Sun Path Diagram for 40 Degrees N Latitude

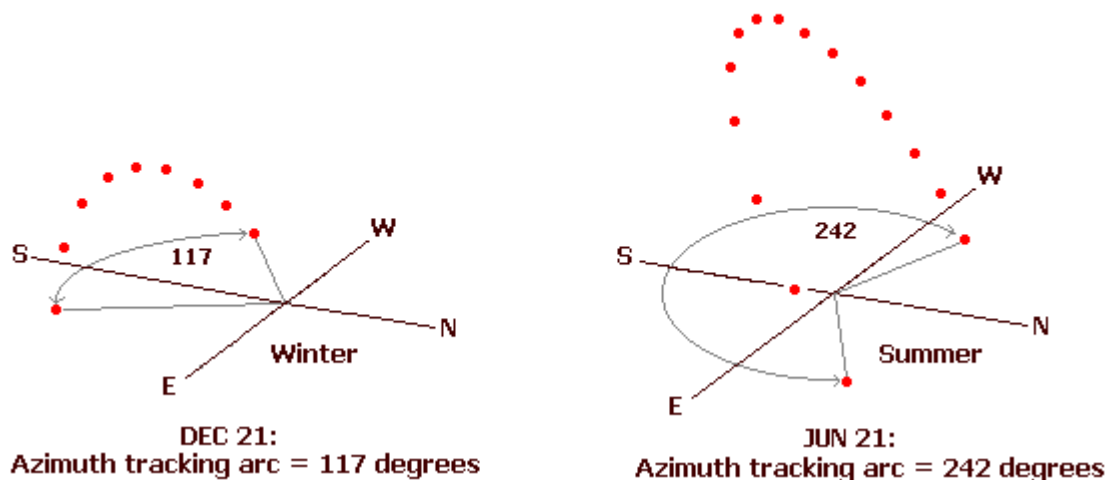

The diagram shows the hourly sun position for 40 Degrees North Latitude. During the winter, a tracker that is powered from an array returns in the morning and captures nearly all the 117-degree azimuth-tracking arc. However, during the summer, 242-degree azimuth-tracking arc is available. A tracker that is powered from an array only captures a 180-degree portion of that arc, and proportionally less power too - even if the tracker limits are set to their extremes.

7.2) On most Azimuth Trackers, the controller is already mounted to the drive head at the factory. The remote sensor and azimuth motor connections are already pre-wired and tested.

Your installer should provide the appropriate fusing or DC breaker to protect any long wire runs and to disconnect to the controller power input.

**7.3) POWER OPTION #1: POWER CONTROLLER FROM A CONSTANT POWER SOURCE:
(24 OR 48 VOLT DC BATTERY BANK OR GRID-TIED AC TO DC SWITCHING POWER SUPPLY)**

- ◆ Powering the tracker controller from a battery bank or Grid-Tied Switching Power Supply is the RECOMMENDED WAY to provide power to your Wattsun Tracker Controller.
- ◆ The controller power-input leads can be connected directly to the main 24-volt battery bank.
- ◆ The tracker returns to the East at sunset and has 270 degrees of azimuth tracking available. The dip-switch, sensor override features built into the controller are always available when you have battery power.
- ◆ If the installation is for a 48-volt system, then you should use a Wattsun Voltage Converter (Part# W48/24 HD or equivalent) to reduce the voltage to the tracker controller and motors.
- ◆ If the installation is for a "Battery-Less" Grid-Tie System, then you should use a Wattsun Switching Power Supply (WDR120-24 or equivalent) to convert AC voltage to 24 VDC.
- ◆ The positive lead running from the battery bank, to the power input of the controller, should be fused with a 5 amp, current limiting, DC-rated fuse or equivalent DC breaker.
- ◆ Failure to fuse the input power wire at the battery bank may create a potential fire hazard.

WARNING! Do not power the controller directly from a 48 VDC battery bank. The "working voltage" of a 48 VDC bank exceeds the controller's 50 VDC maximum input rating. A 48 VDC bank can easily reach 59 VDC during an equalize cycle.

SIMPLIFIED WIRING DIAGRAM FOR BATTERY BANK TO CONTROLLER CIRCUIT

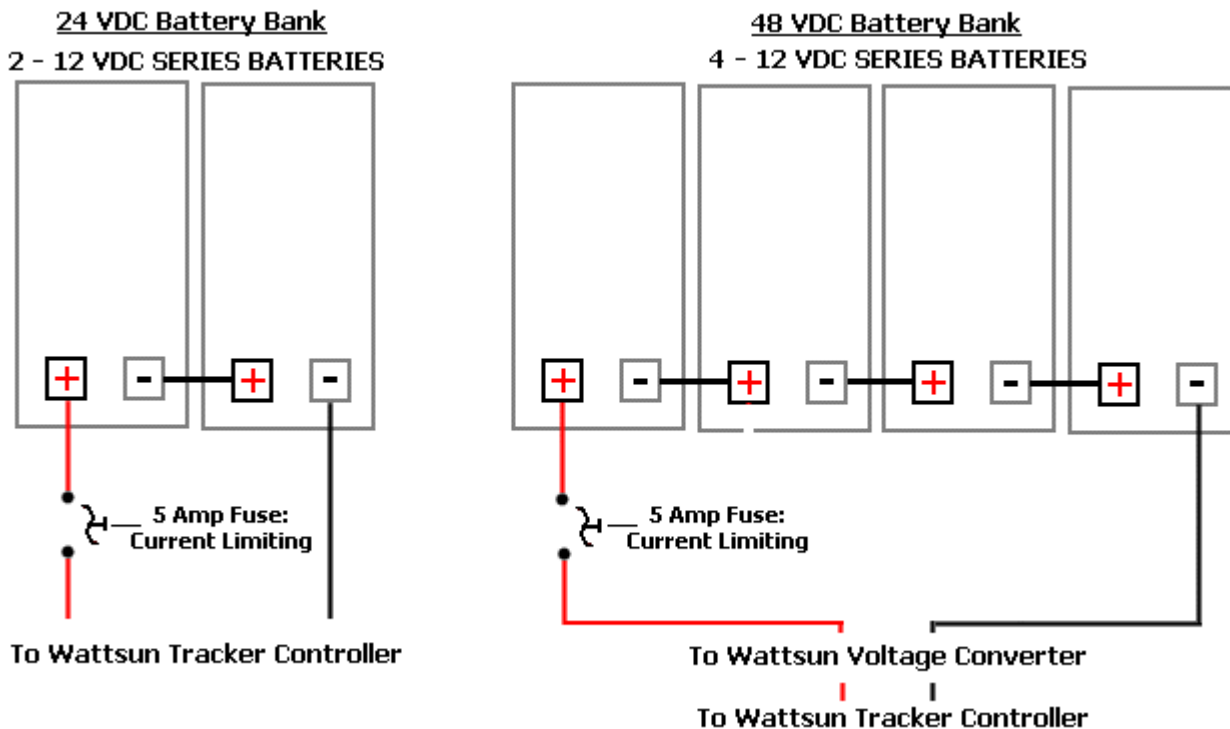

7.4) POWER OPTION #2: POWER THE CONTROLLER FROM A 24 or 48 VOLT PV ARRAY

(Array Technologies does not recommend array direct power connection for Azimuth trackers. Contact your Dealer for assistance if you are using 24 VDC nominal modules with MC Connectors.)

- ◆ Array-direct power limits the daily azimuth tracker rotation to 180 degrees or less.
- ◆ If the installation is for a 48-volt system, then you should use a Wattsun Voltage Converter (Part# W48/24 HD or equivalent) to reduce the voltage to the tracker controller and motors.
- ◆ If the installation is for a "Battery-Less" Grid-Tie System, then you should use a Wattsun Switching Power Supply (WDR120-24 or equivalent) to convert AC voltage to 24 VDC.
- ◆ The positive lead running from the battery bank, to the power input of the controller, should be fused with a 5 amp, current limiting, DC-rated fuse or equivalent DC breaker.
- ◆ Failure to fuse the input power wire at the array may create a potential fire hazard.

The input power leads should be connected to a 24-volt nominal PV array. Typically, this will be the output of two 12-volt PV modules in series. The input voltage should never exceed 50 volts DC and will only operate when the input voltage is above 23 volts. If the 50 VDC maximum input is exceeded, the controller will be damaged. The damage is not covered under warranty.

Typical Open Circuit Voltage, or Voc, of a 24 VDC array is 44 VDC. A 48 VDC nominal array has a Voc of 88 VDC. Array Technologies manufactures a voltage adapter for PV arrays with voltages over 24 VDC. Please contact your Dealer if you need the adapter.

When the controller is powered directly from the PV array, the tracker returns to the east in the morning. The tracker controller automatically adapts to whatever current is available from the PV array. If the PV array is only capable of producing small amounts of current (20 to 300 milliamps) the tracker will move in small, pulsed increments. When the array provides over 1/3 an amp (300 ma) of current, the array moves in a smooth fashion. Typical full east return should occur within 15 minutes after sunrise.

Powering the controller from the array should only be used when limiting the tracker rotation to 180 degrees or less. If the rotation of the tracker is set greater than 180 degrees or if the tracker is not pointed true South, the tracker will be slow to return to the sunrise position in the morning.

BASIC WIRING DIAGRAM FOR ARRAY DIRECT TO CONTROLLER

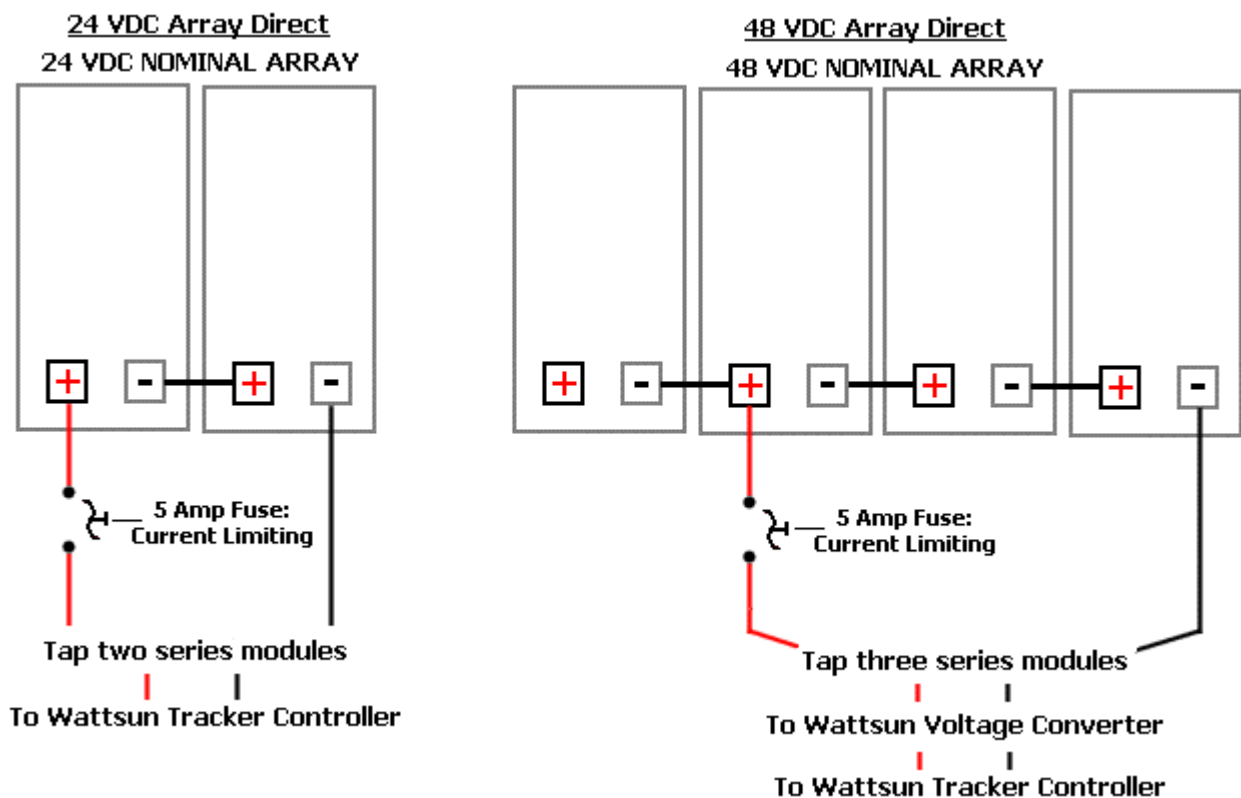

CONTROLLER DIAGRAM, COMPONENTS, SWITCH SETTINGS AND FUSING

Interior View of a Dual-Axis Controller for Azimuth Trackers

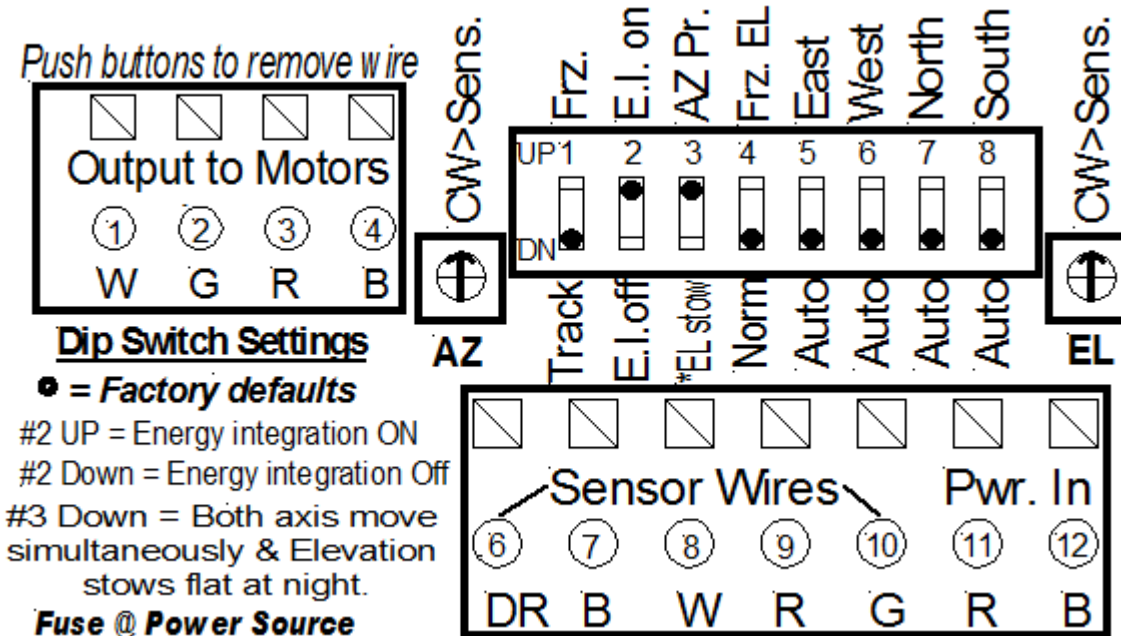

DIP SWITCH SETTINGS

Dip	Default	Up Position	Down Position
#1	Down	Freeze Tracker - Temporary off only	Normal: Auto Track
#2	Up	Normal: Energy Integration ON	Energy Integration OFF: Lowers the voltage input threshold to power from a low state of charge 24 VDC battery.
#3	Up	Normal: Prioritize Azimuth Axis. Move Azimuth 1 st , Elevation 2 nd . Freeze Elevation at night.	Move Azimuth and Elevation at the same time and lay the tracker flat at night. (5 Degree tilt).
#4	Down	Disable Elevation Actuator Auto Track (Winter mode: Maintain a steep tilt to shed snow)	Normal: Dual-Axis Tracking ON
#5	Down	Manually move East.	Normal: Auto Track.
#6	Down	Manually move West.	Normal: Auto Track.
#7	Down	Manually move North.	Normal: Auto Track.
#8	Down	Manually move South.	Normal: Auto Track.

DIP SWITCH

Small rocker switches that affect controller operation. Switches 5,6,7 & 8 move the tracker: allow for a 3 second delay for the motors to engage after "throwing" a switch from Auto Tracking. Return to the Normal position for Auto Tracking!

LIGHT SENSITIVITY TRIM POTS

Inside the controller chassis are two adjustment potentiometers for light sensitivity. They are a single-turn pot: clock-wise rotation equals greater sensitivity, counter clock-wise rotation equals lower sensitivity. This adjustment is factory pre-set and should only be adjusted by qualified personnel. Do not turn more than 1/2 turn in either direction!

INTERIOR FUSE

Replaceable 5-Amp automotive spade type fuse (ATO). Do not replace with a larger amp rated fuse! Gently pull the fuse out of the holder to inspect or replace. It is usual to see a small spark when reconnecting the fuse. A 7.5-Amp fuse is the maximum fuse allowed. A 10-Amp fuse or higher will cause trouble!

OVERVIEW: OPERATING THE TRACKER CONTROLLER AND SETTING THE DIP SWITCH OPTIONS.

Your tracker controller is preinstalled and “ready to go” as soon as you connect power it. The following procedure tests the controller's operation, the full range of motion of the tracker and to set some field selectable options. You can turn the tracker on and off or choose to bypass the Energy Integration Circuit. If you have a Dual-Axis tracker, you can make the tracker lay nearly flat at night or disable the auto-tilt function entirely.

- 8.1) Survey your work area:** You are going to test the tracker range of motion. Be aware that your tracker is set to Auto-Track and will start moving as soon as power is connected to the controller! Make sure that there is nothing in the way of the tracker when it begins to rotate. A common mistake is to leave a ladder standing nearby. Inspect the wiring from the array to the controller and your junction box. Make sure that all wire service loops are long enough and that the wires are free from binding at all pivot points. Is there enough slack in the wires to accommodate full azimuth rotation in either direction?
- 8.2) Remove the controller cover:** Loosen the 4 Phillips bit machine screws and remove the metal cover of the controller. Keep the cover and gasket free of dirt.
- 8.3) Switch #1- Auto Tracking:** Normal position is ON when pushed in at the bottom. Depress the top rocker of Dip Switch #1 to the UP position to temporarily freeze the tracker position. Push in at the bottom to return to Auto Tracking when you are finished testing the controller.
- 8.4) Switch #2- Energy Integration:** Normal position is ON when pushed in at the top. Always Leave UP (E.I. ON) unless you are powering the tracker from a nearly depleted 24VDC battery bank. The down position (E.I. OFF) bypasses the Energy Integration Circuitry. This allows the tracker to operate when the battery voltage is below 23.5 VDC
- 8.5) Switch #3 – Dual Axis, Array Tilt at Night:** Normal position is ON when pushed in at the top. The Azimuth Drive motor operates 1st and the Elevation actuator operates 2nd. At night, the array maintains a steep tilt. When the switch is pushed in at the bottom, both tracker motors can operate at the same time and the array will LAY FLAT at night. Use only in situations where there are high winds and no snow during the evening hours.
- 8.6) Switch #4: Dual Axis, Elevation Tracking:** Normal position is ON when pushed in at the bottom. The tracker will automatically track the sun up and down in the sky. When the switch is pushed in at the bottom, the elevation tracking is stopped. Leave the tracker at a steep tilt. Use in high-latitude sites where the days are short, the sun is low in the sky and snow loading on the array is an issue.
- 8.7) Switch #5:** Normal position is OFF when pushed in at the bottom. Manually move the tracker East by depressing the top of Dip Switch #5. The tracker will track to the East and then stop once the Limit Adjustment Cam touches the limit switch. Return to Normal ON position.
- 8.8) Switch #6:** Normal position is OFF when pushed in at the bottom. Manually move the tracker West by depressing the top of Dip Switch #6. The tracker will track to the West and then stop once the Limit Adjustment Cam touches the limit switch. Return to Normal ON position.
- 8.9) Switch #7:** Normal position is OFF when pushed in at the bottom. Manually move the tracker North (de-elevate) by depressing the top of Dip Switch #7. The tracker will “flatten out” and stop once the elevation actuator's internal limit has been reached. Return to Normal ON position.
- 8.10) Switch #8:** Normal position is OFF when pushed in at the bottom. Manually move the tracker South (elevate) by depressing the top of Dip Switch #8. The tracker will track to the North and then stop once the elevation actuator's internal limit has been reached. Return to Normal ON position.
- 8.11) Setting the Sensor Light Sensitivity:** The sensor sensitivity is preset at the factory. Inside the controller chassis are two adjustment potentiometers for light sensitivity. They are a single-turn pot: clockwise rotation equals greater sensitivity, counter-clockwise rotation equals lower sensitivity. Only qualified personnel should perform this adjustment. Do not turn more than ½ turn in either direction!

VIEW OF A DUAL-AXIS CONTROLLER with V3.3 Sensor

**V3.3 Motor
Wire Connection**

**White
Green
Red
Black**



**DA Option:
Red and Black
(Different than
earlier versions.)**



**To
Motors**

**From
Sensor**

**24 VDC
Power In**



V3.3 Sensor



**Drain
Black
White
Red
Green
Red
Black**
**Sensor
In Power
In**



Sensor is located at the top of the array.

KEEP YOUR FINGERS AND TOOLS AWAY FROM THE GEARING BENEATH THE PROTECTIVE COVER OF THE DRIVE!

The limits for your tracker are preset at the factory. Please contact Array Technologies if you want to change your settings. However, for clarification please review the images below. There are two cams: one stacked atop the other. The bottom cam controls the East limit and the top cam controls the West limit. As the tracker motor operates and moves the tracker, the cams rotate too. Eventually, a "nub" on the cam contacts a limit switch and stops the tracker. The tracker is free to rotate in the opposite direction if the sensor tells it to or if you are in the manual control mode.

The East cam is preset to the maximum East (wide open) position at the factory and acts as a reference for the West cam. The cams are held and meshed together with a retaining spring. Rotate the West cam (top cam) counter-clockwise decrease the westward travel of the array. Make your adjustments in small increments. The only reason to adjust the west cam limit is if the tracker controller is powered from the array. Otherwise do not adjust the limit cam settings.



Do not exceed 135 degrees of rotation West of South or the Worm Gear Assembly will hit a welded safety stop. If you hit the stop the tracker motors will draw too much current and a self-resetting fuse in the controller will shut off the power to the azimuth motor. Turn the tracker controller off using Dip Switch #1, let the fuse cool for 3 minutes, adjust the West cam counterclockwise to reduce the west travel and flip Dip Switch #1 back to the normal operating position. Repeat this process if necessary.

Always test the tracker range of motion after adjusting the cams!

SPECIFICATIONS:

- ◆ **Maximum Voltage Input = 80 VDC, Minimum Input = 36 VDC.**
Power from a 48 VDC battery bank or from three, 12 VDC nominal, modules in series.
- ◆ **Voltage Output at Maximum Input = 24 VDC under load.**
- ◆ **Output Current Maximum = 4.0 A.**
- ◆ **Fuse the 48-24 HD positive input wire with a 5 amp DC-rated fuse.**
Appropriate fuse to be provided by your installer.
- ◆ **All wire color coding is: RED = POSITIVE (+) , BLACK = NEGATIVE(-)**

FUNCTION:

The maximum voltage input for a standard Wattsun Tracker Controller is 50 VDC. PV arrays and battery banks that have a "working" voltage greater than 24 VDC nominal can exceed the 50 VDC threshold. The 48-24 HD regulator limits the voltage input to the tracker controller to a maximum of 24 VDC.



INSTALLING THE 48-24 HD:

- 1) Disconnect the main battery bank or PV array circuit so that no power can flow through any wires you are working on.
- 2) Connect the output of the voltage regulator (longer cable exiting the regulator) to the input power wires of the Wattsun Tracker Controller. IE: Red to Red (+), Black to Black (-).
- 3) Fuse the input of the voltage regulator (shorter cable side) with a 5 amp DC rated fuse. The fuse is inserted in the positive (Red,+) lead of the input wire.
4. A) Battery bank connection: Connect the fused input side (two-wire, shorter cable) of the voltage regulator directly to the output of a 48-volt battery bank. Battery positive to fused red input. Battery negative to voltage regulator input negative.
4. B) PV array direct connection: Connect the fused input side (two-wire, shorter cable) of the voltage regulator directly to the output of three, 12- volt modules in series. When connecting directly to the PV Array: You will want to make the connection on the lower side of the 4-module string. IE: From the negative of array to the positive tap of the third module, in the 4-module, 48 VDC nominal string.
- 5) Open the Wattsun Solar Tracker Controller and set switch #2 to the UP (PV) Energy Integration setting.
- 6) Reconnect the main battery bank or PV array circuit so that power can flow through the voltage regulator and Wattsun Solar Tracker Controller.

WARNING!

- ◆ **Connection to the output of 4-modules in series will exceed the 80 VDC maximum input of the voltage regulator. The 48-24 HD will be damaged and cause the Wattsun Solar Tracker Controller to fail. Warranty does not cover this damage. Both parts will have to be returned to the factory for repair!**
- ◆ **Never apply power into the 48-24 HD output wires. Warranty does not cover this damage. Damage can occur and it will have to be returned to the factory for repair!**
- ◆ **A self-resetting fuse is incorporated in the 48-24 HD. If the output wires touch each other and are shorted, the interior fuse can blow and will disconnect the power output of the regulator. If this happens: Repair the output short then reset the fuse. Disconnecting power to the regulator resets the fuse. Wait a minute for the fuse to cool. Then reconnect power to the regulator.**

CAUTION!

CONVERTOR CASE MAY GET VERY HOT UNDER HIGH LOAD OR SHORT CIRCUIT. DO NOT MOUNT TO A FLAMABLE SURFACE SUCH AS WOOD. DO NOT LET CHASSIS COME INTO CONTACT WITH OTHER WIRES AS HEAT MAY MELT THE INSULATION.

Wiring Diagram for a Wattsun 48-24 HD

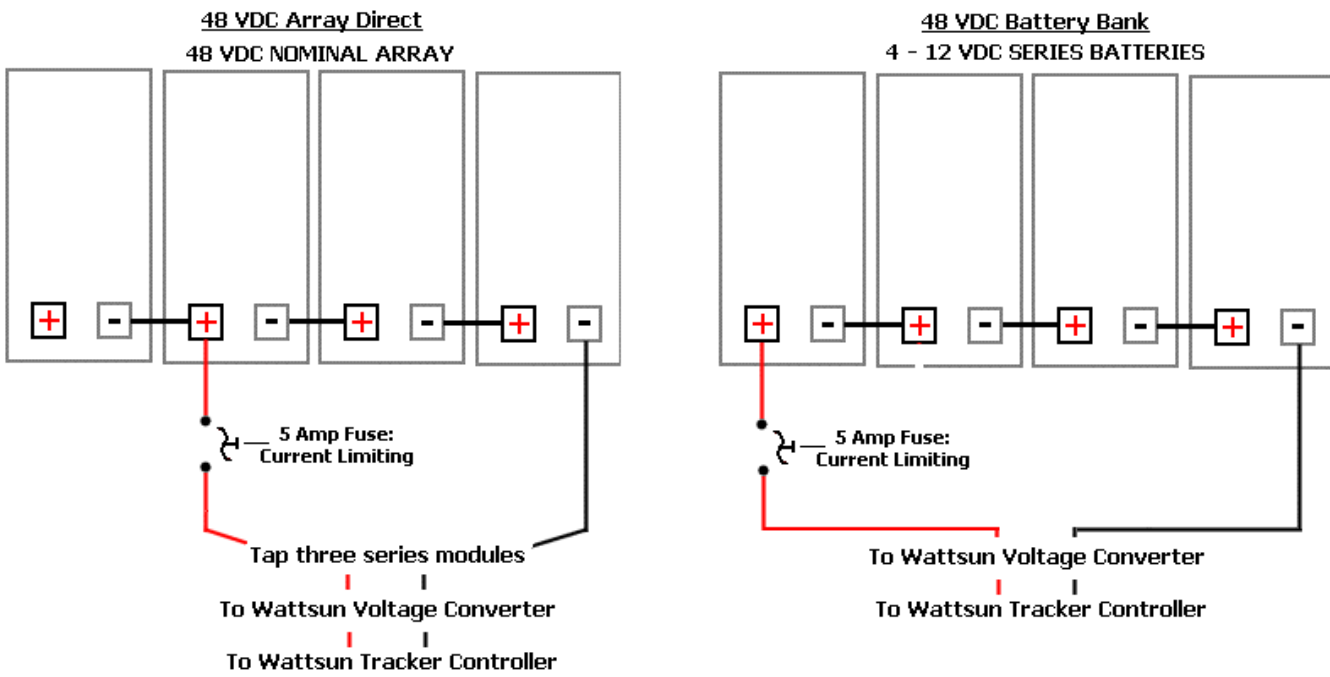

**FUNCTION:**

Most manual controls are installed on Wattsun Dual-Axis Trackers rather than on Single-Axis Units. The Manual Control Option allows the user to bypass automatic tracking and to move the tracker East, West, North, or South. The Manual Control Option is typically installed on your tracker before it leaves Array Technologies. However it is available as an upgrade kit that can be installed in the field.

The Manual Control Option requires that power be available to the Wattsun Tracker Controller. If the controller is connected to the main battery bank, then you can use the manual controls day or night. If you power the tracker controller from the array, then you will be limited to the daylight hours.

HIGH WIND AREAS:

If the tracker is run to a full North position, the array lays flat in a horizontal stow position. This is especially useful if you experience very strong winds or tropical storms and you want to reduce the wind loading on your tracker.

HIGH SNOW AREAS:

If the tracker is run to a full South position, the array elevates up to a 75-degree angle. This is useful for dumping any snow accumulation on the array.

SWITCHES:

Automatic / Manual - Flip Down for Auto Tracking or flip Up to enable Manual Tracking.

East / West - Hold left to track East or hold right to track West.

North / South - Hold up to track South (elevate) or hold down to track North (flatten).

12) PERIODIC MAINTENANCE

- ◆ Maintenance should be performed at least once a year. More often if your tracker is installed in severe weather areas.
- ◆ Inspect all the tracker hardware and the module bolts for tightness. Tighten all nuts and bolts that need it.
- ◆ Inspect all wires for abrasion and gently tug on them to make sure that they are secure.
- ◆ Each of the four grease zerks should receive 4-6 pumps of lithium-base general-purpose chassis grease from a grease gun.
- ◆ Elevation Actuator: Spray the inner tube (telescoping part) of the linear actuator with a lubricating rust inhibitor. (We use LPS-3)

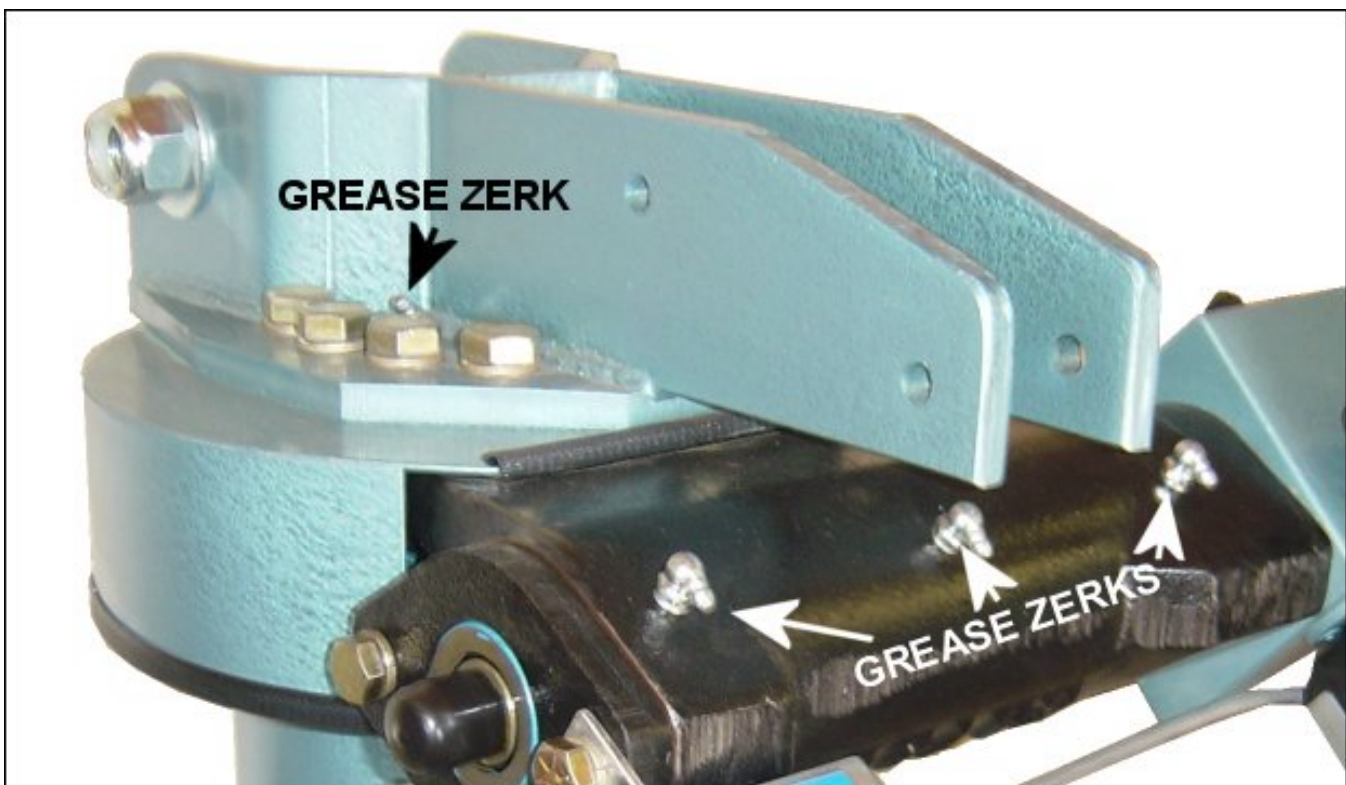

WARNING!

- The information provided here is a general guideline for grounding your Wattsun Solar Tracker.
- This information is not a substitute for following the National Electrical Code.
- You should hire a qualified Electrician, Electrical Contractor or Solar Professional to install and wire your Wattsun Solar Tracker.
- Array Technologies does not assume any liability for your failure to adhere to the NEC.
- Failure to ground your tracker may void your Wattsun Warranty and may result in damage to your Wattsun Solar Tracker Controller or motors.

REFERENCES:

Code Corner Columns available online at: <http://www.nmsu.edu/~tdi/codecorner.htm>

FIG 1: GROUNDING THE MODULES, TRACKER FRAME, DRIVE AND MOUNTING PIPE

The array equipment-grounding conductors, for the modules, tracker frame, drive and mounting-pipe, should terminate at one location—probably a grounding terminal strip in the junction/combiner box. Then, there should be a conductor from this point to the grounding electrode (ground rod).

The steps are:

- The frame of every module is interconnected with grounding wire.
- The module grounding wire ties into the tracker frame on the torque tube or struts.
- A flexible loop of grounding wire continues from the torque tube to the base of the drive.
- The ground wire continues to the mounting pipe or combiner box that is bonded to the pipe.
- The ground wire goes down the pole and is bonded to an 8-foot copper ground rod.
- The ground rod is set in the earth outside of the concrete foundation of the pipe.
- Do not rely on the mounting pipe to act as a ground rod.

(Older AZ200 shown for illustration purposes)

FIG 1
Grounding a Wattsun Tracker

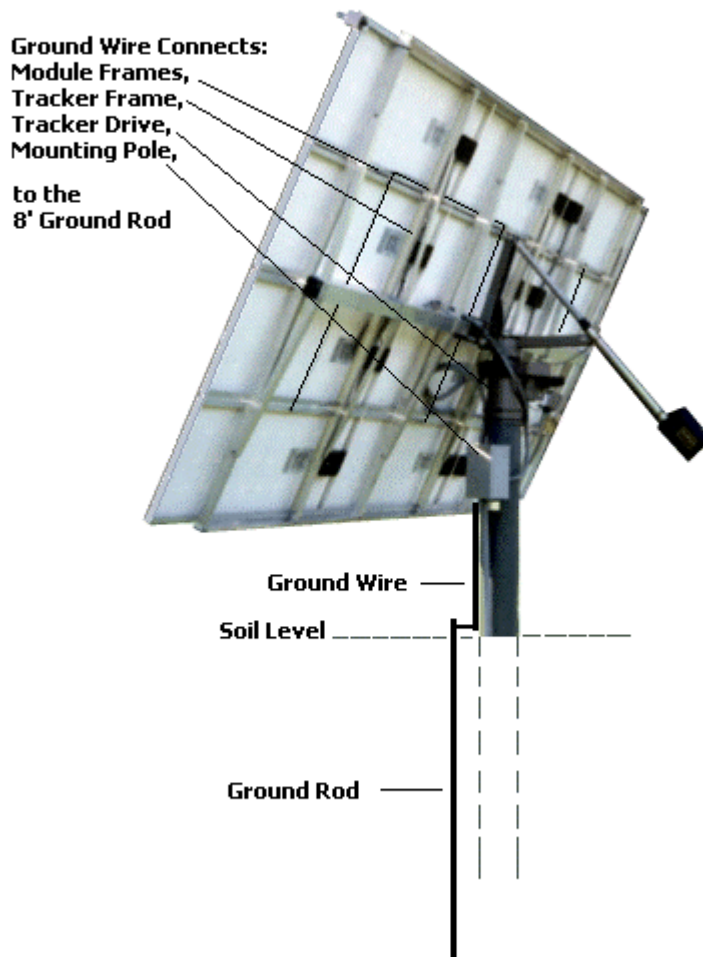
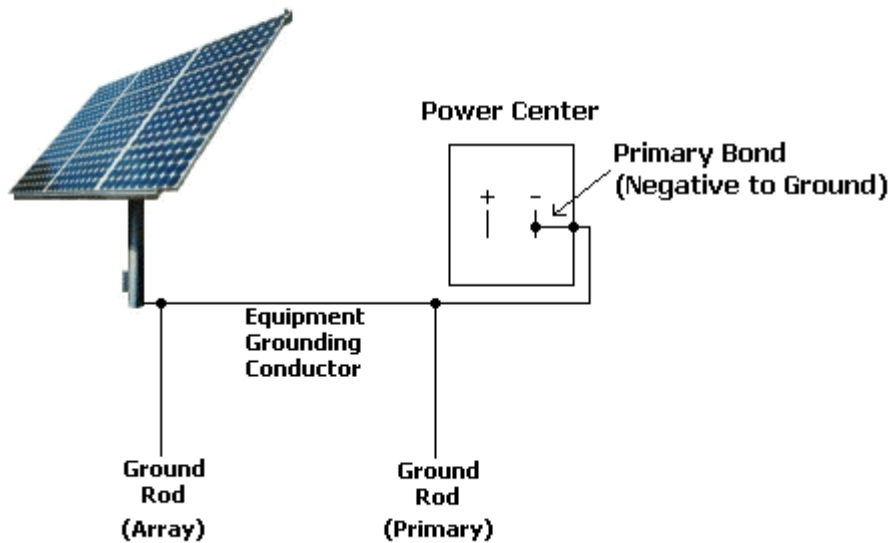

FIG 2: TYPICAL GROUNDING OF A TRACKER TO THE BATTERY BANK/POWERCENTER.

- The modules, Wattsun Tracker, and mounting pipe are grounded as shown in Figure 1.
- The normal, (primary bond) negative-to-ground bonding is required in the power center or ground-fault device.
- The negative current-carrying (PV Negative) conductor is bonded (connected) to the grounding system at the power center or charge controller.
- An equipment-grounding conductor is run from the PV array to the power center or charge controller.

FIG 2
Grounding a Wattsun Tracker that is located close to the battery bank.



WARNING!

If you ground according to FIG 2, you must ground the PV Negative at the powercenter, not at the array. There can only be one ground for the current carrying conductor (PV Negative) in this situation.

FIG 3: ALTERNATIVE GROUNDING FOR A TRACKER THAT IS DISTANT FROM THE BATTERY BANK/POWERCENTER.

- The modules, Wattsun Tracker, and mounting pipe are grounded as shown in Figure 1.
- The PV array is ground mounted some distance (perhaps over 30 feet) away from other PV components (inverter, batteries, etc.). The distance is not specified in the NEC.
- There are no AC power circuits between the array and the bank/powercenter.
- There are no conductive paths (electrical or other) such as water pipes, metal fences, communication circuits, or telephone circuits between the array and the other structure.
- Bond the negative conductor (PV Negative) to the grounding system at both the array and at the inverter/battery/power center location.
- Do not run any equipment grounding conductors between the array and at the inverter/battery/power center location.
- Use ground rods at the array and at the inverter/battery/power center location.

**FIG 3
Grounding a Wattsun Tracker that is over
30 feet from the battery bank**

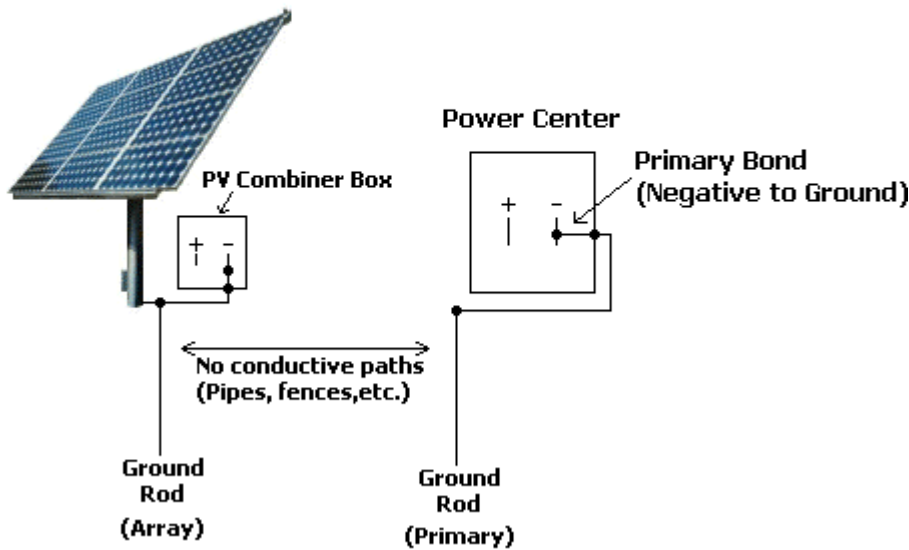

WARNING!

If you ground according to FIG 3, you must ground the PV Negative at both the array and at the powercenter. Do not run any equipment grounding conductors between the array and at the inverter/battery/power center location.

Array Technologies, Inc. warrants its Wattsun™ Solar Trackers to the original consumer purchaser that it will repair, or replace, at Array Technologies Inc.'s option, any Wattsun™ Tracker component that is determined to be defective in material or workmanship for the following terms:

Two years from date of purchase on all components including tracker controller, frame, azimuth drive assembly, and actuator.

To be eligible for repair or replacement under this warranty, the part in question must be sent to Array Technologies, Inc. within the warranty period and the original consumer purchaser must comply with the following conditions:

- ◆ The tracker or component thereof must not have been modified or altered in any way by an unauthorized source.
- ◆ The tracker or component thereof must have been installed in accordance with the installation instructions including electrical connections of tracking controller.

This limited warranty does not cover:

- ◆ Damage due to improper or installation;
- ◆ Accidental or intentional damage;
- ◆ Misuse, abuse, corrosion, or neglect;
- ◆ Products impaired by severe conditions, such as excessive wind, ice, storms or other natural occurrences;
- ◆ Trackers used for purposes other than the intended use, including mounting modules or components which the tracker was not intended for;
- ◆ Trackers with more than the intended number and type of modules mounted on it;
- ◆ Damage due to improper packaging on return shipment.

Any and all labor charges for troubleshooting, removal or replacement of tracker and/or components of the tracker are not covered by this warranty and will not be honored by Array Technologies, Inc.

Return shipping is to be pre-paid by the original consumer purchaser. Array Technologies, Inc. will pay the normal return UPS shipping charges within the USA only.

THIS WARRANTY IS EXPRESSLY IN LIEU OF ALL OTHER WARRANTIES OF ANY KIND, EXPRESSED OR IMPLIED, INCLUDING (WITHOUT LIMITATION) ANY IMPLIED WARRANTIES OF MERCHANTABILITY OR FITNESS FOR A PARTICULAR PURPOSE, AND OF ANY NONCONTRACTUAL LIABILITIES BASED UPON NEGLIGENCE OR STRICT LIABILITY. IN NO EVENT SHALL ARRAY TECHNOLOGIES, INC. BE LIABLE FOR INCIDENTAL OR CONSEQUENTIAL DAMAGES, INCLUDING (WITHOUT LIMITATIONS) ANY DAMAGE FOR PERSONAL INJURY OR PROPERTY DAMAGE OR OTHER PRODUCT LIABILITIES BASED UPON ALLEGED NEGLIGENCE OR BREACH OF EXPRESS OR IMPLIED WARRANTIES OR STRICT LIABILITY. ARRAY TECHNOLOGIES, INC. NEITHER ASSUMES NOR AUTHORIZES ANY OTHER PERSON TO ASSUME FOR IT ANY OTHER OBLIGATION IN CONNECTION WITH THE SALE OF ITS WATTSUN™ SOLAR TRACKERS.

THIS WARRANTY GIVES YOU SPECIFIC LEGAL RIGHTS, AND YOU ALSO MAY HAVE OTHER RIGHTS THAT MAY VARY FROM STATE TO STATE. SOME STATES DO NOT ALLOW LIMITATIONS ON HOW LONG AN IMPLIED WARRANTY WILL LAST OR THE EXCLUSION OR LIMITATION OF INCIDENTAL OR CONSEQUENTIAL DAMAGES, SO THE ABOVE LIMITATIONS OR EXCLUSIONS MAY NOT APPLY TO YOU.

**Array Technologies, Inc.
3312 Stanford NE
Albuquerque, NM 87107**

**Tel: 505-881-7567
Fax: 505-881-7572
URL: www.wattsun.com**

Addendum: "Über Tracker" Plate Assembly for HZ Torque Tubes

AZ-225 Saddle Clamp Assembly (Largest "Uber" Tracker Models)

Galvanized Torque Tube

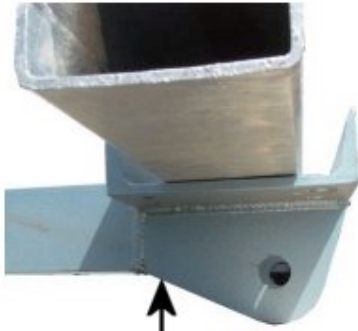

Lower Channel

Top Channel



Lower Channel

Channel Bolts

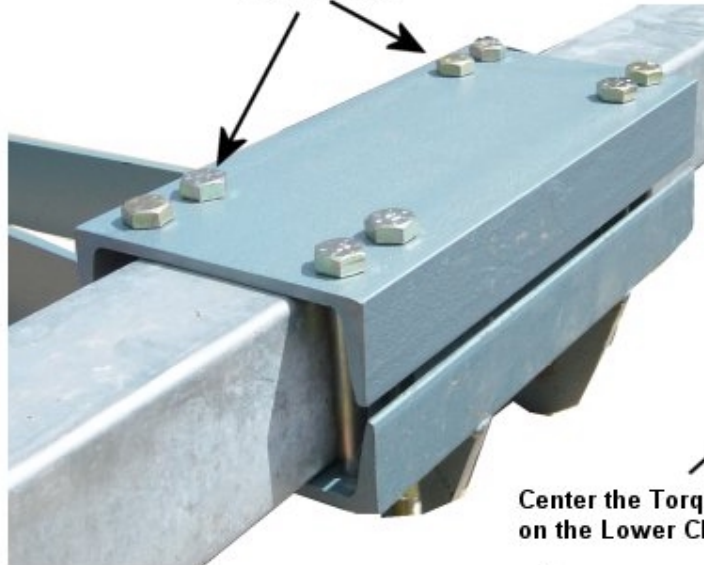

Center the Torque Tube
on the Lower Channel